

# TITAN<sup>®</sup>

L I F T S

## INSTALLATION, OPERATION, & MAINTENANCE MANUAL



### MODEL:

**HD2P-9000AFE**

**9,000 LB CAPACITY 2 POST LIFT**

**⚠ FOLLOW THIS MANUAL CAREFULLY TO ENSURE THE EQUIPMENT WILL FUNCTION CORRECTLY AND PROVIDE MANY YEARS OF DEPENDABLE SERVICE. FAILURE TO FOLLOW THESE INSTRUCTIONS AND SAFETY WARNINGS MAY RESULT IN PERSONAL INJURY OR PROPERTY DAMAGE. KEEP THIS MANUAL IN A SAFE, DRY PLACE FOR FUTURE REFERENCE.**



**TITAN MARKETING, LLC**

PO Box 7069 Greenwood, IN 46142  
1.888.908-4826 FAX (317) 215.2770  
[www.titanlifts.com](http://www.titanlifts.com)

To Our Valued Customers:

Thank you for purchasing a Titan Lifts® product. We hope this high quality equipment provides you with years of dependable service.

It is unfortunate that rare situations may occur with the products you purchase from Titan Lifts®. We value your business as well as the trust you have and need to maintain your relationship with us. Titan Lifts® carries liability coverage that may protect our customers if a situation does occur. However, as in all accidents there must be proof of liability for a claim to be made. Our insurance company requires the following procedures be observed in order to consider a claim:

- A. The claimant must contact the Titan Lifts® distributor immediately with the facts of the situation.
- B. If any equipment is damaged, including vehicles or shop equipment, Titan Lifts® must be given the opportunity to send an impartial representative to the site for proper assessment of the situation.
- C. The Vehicle cannot be moved until either an impartial representative has reviewed the accident or clear and precise pictures are taken that reflect all the pertinent information for an impartial representative to be able to assess the information from a distance. Titan Lifts® or its representatives must approve the pictures before anything can be moved.
- D. If any potential liability is determined on behalf of Titan Lifts®, two estimates must be submitted for damages to be reimbursed.

It is imperative that the claimant complies with these procedures, because without proper assessment of the situation a claim will be denied.

**ARBITRATION NOTICE**

The installation or use of this equipment shall constitute an acknowledgement that the user agrees to resolve any and all disputes or claims of any kind whatsoever, which relate in any way to the equipment, by way of binding arbitration, not litigation. No suit or legal action may be filed in any state or federal court. Any arbitration shall be governed by the Federal Arbitration Act, and administered by the American Mediation Association, Indianapolis Indiana. The maximum amount that an arbitrator may award and all damages shall not exceed the retail value of this equipment.

**WARRANTY NOTICE**

This equipment must be installed by a "Professional Installer" assembled and used in the manner according to the documentation provided to be covered by warranty.

Damaged or missing components must be reported within 72 hours of receipt to your freight carrier and to the distributor. Claims must be filed to cover cost.

If you have any questions or if we can be of any further assistance, please don't hesitate to contact a Titan Lifts® representative at 1-888-908-4826. Thank you for the opportunity to continue to serve your lift equipment needs.

# CONTENT

<b>1. Safety .....</b>	<b>Page 1</b>
1.1 Introduction .....	Page 1
1.2 Safety Instructions for Commissioning .....	Page 1
1.3 Safety Instructions for Operation.....	Page 1
1.4 Safety Instructions for Maintenance.....	Page 3
1.5 Risks .....	Page 3
1.6 Description .....	Page 4
<b>2. Unpacking and set-up .....</b>	<b>Page 5</b>
2.1 Delivery & check of packages .....	Page 5
2.2 Lifting & handling.....	Page 5
2.3 Preparation.....	Page 5
<b>3. Specifications .....</b>	<b>Page 8</b>
<b>4. Floor Requirements.....</b>	<b>Page 8</b>
4.1 Select the site area .....	Page 8
4.2 Floor Requirements.....	Page 8
4.3 Concrete and Anchoring Information.....	Page 9
4.4 Anchoring tips.....	Page 10
<b>5. Installation Instructions .....</b>	<b>Page 11</b>
<b>6. Operation Instructions .....</b>	<b>Page 17</b>
6.1 Defects / Malfunctions.....	Page 17
6.2 Controls .....	Page 17
6.2.1 Up Controls .....	Page 17
6.2.2 Safety Lock Control.....	Page 17
6.2.3 Lowering Control .....	Page 18
6.3 Operation .....	Page 18
<b>7. Maintenance.....</b>	<b>Page 20</b>
7.1 Maintenance Schedule.....	Page 20
7.1.1 Daily .....	Page 20
7.1.2 Weekly.....	Page 20
7.1.3 Monthly.....	Page 21
7.1.4 Bimonthly .....	Page 21
7.1.5 Yearly .....	Page 21
7.1.6 Every Other Year .....	Page 22
7.2 Maintenance by the Operator.....	Page 22
7.2.1 Hydraulic System .....	Page 22
7.2.2 Greasing Points.....	Page 23
7.2.3 Operation and Wear Checks.....	Page 23
7.2.4 Lift Stability.....	Page 23
7.3 Cleaning .....	Page 23
<b>8. Troubleshooting .....</b>	<b>Page 24</b>
<b>9. Owner / Employer Responsibilities .....</b>	<b>Page 26</b>
<b>10. Diagrams Fig. 1-9 .....</b>	<b>Page 27</b>
<b>11. Parts Diagrams .....</b>	<b>Page 38</b>

# INSTRUCTIONS

## 1.SAFETY

### 1.1 INTRODUCTION



**WARNING:** READ ENTIRE MANUAL AND COMPLY WITH ALL SAFETY AND SERVICE PRECAUTIONS. DEATH, PERSONAL INJURY AND / OR PROPERTY DAMAGE MAY OCCUR IF INSTRUCTIONS ARE NOT FOLLOWED CAREFULLY.

Personal injury and property damage incurred due to non-compliance with these safety instructions are not covered by the product liability regulations.

### SYMBOLS

---



**FAILURE TO COMPLY WITH INSTRUCTIONS COULD RESULT IN PERSONAL INJURY.**

---



**FAILURE TO COMPLY WITH INSTRUCTIONS COULD RESULT IN PROPERTY DAMAGE.**

---



**IMPORTANT INFORMATION.**

---

### 1.2 SAFETY INSTRUCTIONS FOR COMMISSIONING

- The lift may be installed and commissioned by authorized service personnel only.
- The standard lift version may not be installed and commissioned in the vicinity of explosives or flammable liquids, outdoors or in moist rooms (e.g. car wash).

### 1.3 SAFETY INSTRUCTIONS FOR OPERATION

- Read this entire manual.
- Load should not exceed rated capacity for this lift – 9,000 lbs. **(2,250 lbs per lift arm)**
- Only trained authorized personnel over the age of 18 years should operate the lift.
- Indoor use recommended.
- Always lift the vehicle using all four arms.
- Never use the lift to raise one end or one side of vehicle.

- Maintain a safe working environment. The work area should be clean, dry, clutter free, and sufficiently lit.
- Vehicle doors should be closed during the raising and lowering cycles.
- Closely watch the vehicle and lift during the raising and lowering cycles.
- Do not operate the lift in explosive atmospheres, such as in the presence of flammable liquids, gases, or dust. Power equipment can create sparks which may ignite flammables.
- Keep hands, tools, and other extremities from under carriage and moving parts.
- Never operate this lift with someone on it.
- Do not allow anyone on the lift or inside a raised vehicle.
- Keep children and bystanders away from work area. Do not let children operate or play on lift.
- Wear proper safety attire. Do not wear loose fitting clothing while operating lift. Long hair, jewelry and sleeves should be secured.
- Never leave the lift unattended while under a load.
- Do not operate this lift if under the influence of drugs, alcohol, or medication. Operator must be alert at all times when using heavy lift equipment.
- Comply with all applicable accident prevention regulations.
- Only use the vehicle manufacturer's recommended lifting points.
- After positioning the vehicle, apply the parking brake.
- Use caution when removing or installing heavy vehicle components which may result in center-of-gravity displacement.
- Use this lift only for the work it is intended. Do not use this product for an application for which it was not designed. Misuse can lead to personal injury and/or property damage.



**WARNING:** Prior to completely raising the vehicle, raise the vehicle 6" off the ground and check the adapter pads for solid contact by performing the "BUMPER TEST". Walk around the back of the vehicle and push up and down on the bumper. The vehicle will rock, but should not at any time lose contact with the pads. If the vehicle is bouncing off the pads or feels at all unstable, you should lower it back to the ground and reposition the pads to balance the load. Repeat this process until the vehicle is completely stable.



**WARNING:** Use this lift only in well ventilated areas. Carbon monoxide exhausted from running vehicle engines is a colorless, odorless fume that, if inhaled, can cause serious personal injury or death.



**WARNING:** People with pacemakers should consult their physician(s) before using this product. Operation of electrical equipment in close proximity to a heart pacemaker could cause interference or failure of the pacemaker.



**WARNING:** This product contains or produces a chemical known to the State of California to cause cancer and birth defects (or other reproductive harm). (California Health & Safety Code 25249.5 et seq.)

## 1.4 SAFETY INSTRUCTIONS FOR MAINTENANCE

- Maintenance or repair work should be done by authorized service personnel only.
- Work on the electrical equipment should be done by certified licensed electricians only.
- Ensure that ecologically harmful substances are disposed of in accordance with the appropriate regulations.
- To prevent the risk of damage, do not use high pressure / steam jet cleaners or caustic cleaning agents.
- Do not replace or override the safety devices.

## 1.5 RISKS



**WARNING:** Risks the personnel could encounter, due to an improper use of the lift, are described in this section.

### CRUSHING RISK

During lowering of runways and vehicles, personnel must not be within the area covered by the lowering trajectory. The operator must be sure no one is in danger before operating the lift. Stay clear of the lift when lowering or raising vehicles. Keep hands and feet away from moving parts and especially points that could pinch. Keep your feet clear of the lift when raising and lowering vehicles.

### BUMPING RISK

When the lift is stopped at relatively low working height, the risk of bumping against projecting parts increases. Always be aware of your surroundings and avoid bumping your head or body on the lift or the vehicle.

### RISK OF THE VEHICLE FALLING FROM THE LIFT

Risk of the vehicle falling from the lift is increased: when the vehicle is improperly placed on the platforms, when the vehicle's weight or physical dimensions exceed the rated capacity of the lift, or when there is excessive movement of the vehicle while on the lift. If vehicle appears to begin falling, exit the area as quickly as possible to avoid injury. Always position vehicle with the center of gravity midway between the adapters. Adding or removing parts of a vehicle on the lift will alter the weight displacement on the lift. Therefore, use of auxiliary safety stands in the front and back of the vehicle is recommended. Never override the manufactured lift controls. Always use height adapter pads when possible to ensure proper contact. Only authorized personnel should be allowed in the lift area and the lift should only be operated by authorized and trained personnel. Adding or removing parts of a vehicle on the lift will alter the weight displacement on the lift.

# 1.6 DESCRIPTION

The model numbers covered in this manual are designated below:

**HD2P-9000AFE:** 2-Column Hydraulic Lift, Floor Plate type, 9000 lbs. Capacity, leaf chain driven, Asymmetric Swing Arm set up, dual point lock release.

This lift is a 9000 lb. capacity, 2-Post Lift. Heavy bearings and heavy-duty leaf chains are used throughout the lift. The work is done with the heavy-duty chain connected to a 2-1/2" cylinder, driven by a hydraulic pump capable of providing 3,000 psi. During the lifting process, the safety lock will automatically engage. The safety latch system is very similar to an extension ladder. The safety latch is in contact with the rack as the lift ascends and drops into place as the lift rises. Safety latch engages in rack in 3" increments starting at about 16" from the ground. The latches must be manually disengaged for the lift to descend. The latches are released by pulling the release cables raising the latches up off the latch racks. Once the raise button is pressed, the latch will automatically re-engage after approximately 3" of travel.

Please read the Safety Procedures and operation instructions in this manual before operating the lift. Proper installation is very important. To minimize the chance of making an error in installation, please read this manual thoroughly before beginning installation. Check with building owner and/or architect's building plans when applicable. The lift should be located on a level floor with 4" 3000 psi concrete sufficiently cured, for at least 30 days.

This is a vehicle lift installation / operation manual and no attempt is made or implied herein to instruct the user in lifting methods particular to an individual application. Rather, the contents of this manual are intended as a basis for operation and maintenance of the unit as it stands alone or as it is intended and anticipated to be used in conjunction with other equipment.

Proper application of the equipment described herein is limited to the parameters detailed in the specifications and the uses set forth in the descriptive passages. Any other proposed application of this equipment should be documented and submitted in writing to the factory for examination. The user assumes full responsibility for any equipment damage, personal injury, or alteration of the equipment described in this manual or any subsequent damages.

## **2. UNPACKING, & SET-UP**

Only skilled personnel who are familiar with the lift and this manual shall be allowed to carry out, lifting, handling, transport and unpacking operations.

### **2.1 DELIVERY AND CHECK OF PACKAGES**

When the lift is delivered, carefully unpack the lift making sure all the parts have been included. Check for possible damages due to transport and storage; verify that what is specified in the confirmation of order is included. In case of damage in transit, the customer must immediately inform the carrier of the problem.

Remove the lift and all parts from delivery pallet and place on a clean, solid, flat surface. Packages must be opened paying attention not to cause damage to people (keep a safe distance when opening straps) and parts of the lift (be careful the objects do not drop from the package when opening.) Refer to the following diagram and packing list for checking in components.

### **2.2 LIFTING AND HANDLING**

When loading/unloading or transporting the equipment to the site, be sure to use suitable loading (e.g. cranes, trucks) and hoisting means. Be sure to hoist and transport the components securely so that they cannot drop, taking into consideration the package's size, weight, center of gravity, and it's fragile parts.



**LIFT AND HANDLE ONLY ONE PACKAGE AT A TIME**

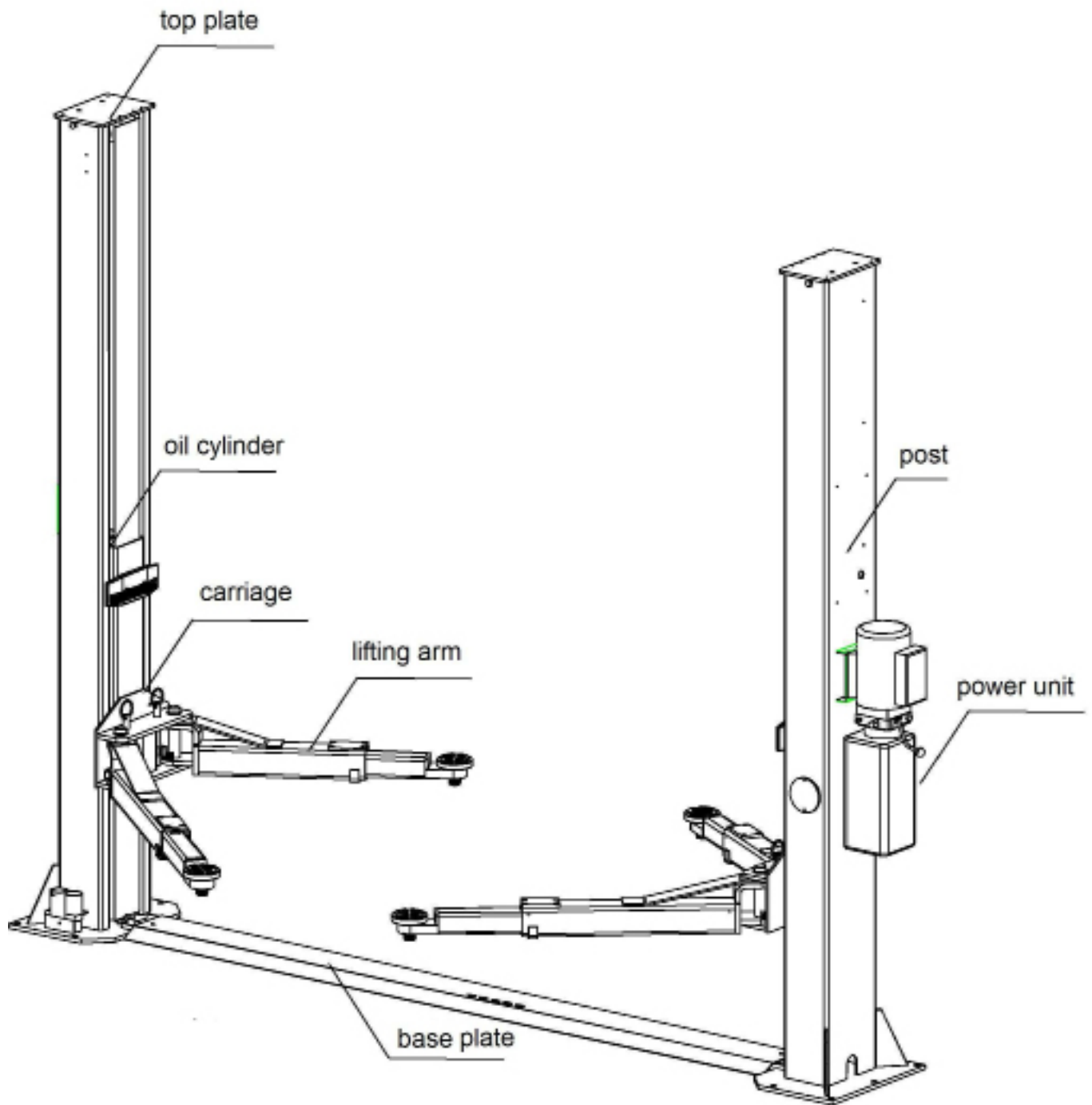
### **2.3 PREPARATION**

The installation of this lift is relatively simple and can be accomplished by 2 men in a few hours. The following tools and equipment are recommended:

1. ISO-32, AW-32, or AW-46 hydraulic oil or other premium quality ATF DEXRON-III / MERCON
2. Chalk Line and Tape Measure
3. Rotary Hammer Drill with 3/4" Drill Bit. Core Drill Rebar Cutter recommended
4. Transit and a 4' Level
5. Sockets and Open Wrench set, 1/2" thru 1-1/2"(1-1/8"for 3/4" Anchors)
6. Vise Grips
7. Torque Wrench



# LIFT COMPONENTS



# COMPLETE PACKING LIST

No.	Material #	Name	Size	Property	Qty
1	615003004	Power-side post		Assembly	1
2	615003005	Post		Assembly	1
3	615003001	Carriage		Assembly	2
4	615004004	Long arm assembly		Assembly	2
5	615004005	Short arm assembly		Assembly	2
6	615001006	Oil cylinder		Assembly	1
7	615001007	Drive oil cylinder		Assembly	1
8		Hydraulic pump		Assembly	1
9	410040013	Base cover plate		Q235A	1
10	614004017	Slot base plate		Welded	1
12	615001010	Steel cable	8785mm	Assembly	2
13		Power unit package			1
14		Parts included in the carton			1
15	420010020B	Door-opening protection		Rubber	2
16	624001024	Rubber oil hose	1400mm	Assembly	1
17	624001025	Rubber oil hose	2880mm	Assembly	1
18	410010051	Hook for chain protection cloth		Zinc-plating	4
19	615004003B	Lifting tray		Assembly	4
20	614004014	Long arm fender		Powder-coating	2
21	614004013	Short arm fender		Powder-coating	2
22	612004003	Height adapter		Zinc-plating	4
23	612004004	Shaft		Zinc-plating	4
24	615001002	Chain protection cloth		Assembly	2
25	201102019	Hex head full swivel screw	M10*30	Standard	4
26	202110004	Hex socket button head screw	M8*12	Standard	8
27	202103021	Cross sunken screw	M8*16	Standard	4
28	202101027	Cross cap screw	M6*8	Standard	4
29	204101004	Flat washer	M6	Standard	8
30	204101006	Flat washer	M10	Standard	4
31	204201005	Spring washer	M10	Standard	4
32	203101006	Hex nut	M10	Standard	4
33	203101004	Hex nut	M6	Standard	8
34	204301013	Circlip	38	Standard	4
35	201201007	Expansion bolt	M18*160	Standard	10

# 3. SPECIFICATIONS

Model	Description	Capacity	Lifting Time	Overall Height	Overall Width	Between Posts
HD2P-9000AFE	Floor Plate/ Asymmetric	9,000 lbs	55 sec.	111"	134 5/8"	111 3/8"

# 4. FLOOR REQUIREMENT

These notes are for your guidance prior to installation

## 4.1 SELECTING THE SITE AREA

1. Make sure that adequate space and height is available.
2. Check for ceiling clearance (lifting height plus vehicle height).
3. Check for clearance in front and rear of vehicle on lift.
4. Check for overhead garage door clearance.

## 4.2 FLOOR REQUIREMENTS

Do not use the lift on any asphalt surface. Make sure the lift is used on a dry, oil/grease free, flat level CONCRETE surface capable of supporting the weight of the lift, the vehicle being lifted, and any additional tools and equipment. The concrete floor surface should have a minimum thickness of 4". The concrete must have a minimum strength of 3,000 PSI, and should be aged at least 30 days prior to use. Do not use the lift near concrete expansion seams or on cracked, defective concrete.



**WARNING: SPECIFICATIONS OF CONCRETE MUST BE ADHERED TO. FAILURE TO DO SO COULD CAUSE LIFT FAILURE RESULTING IN PERSONAL INJURY OR DEATH. THE FLOOR SHOULD BE A REINFORCED CONCRETE SLAB NOT LESS THAN 4" (101.6MM) THICK WITH THE COMPRESSIVE STRENGTH OF THE CONCRETE NO LESS THAN 3,000 PSI (20.68MPA).**



**DANGER: FOR CORRECT INSTALLATION OF THE LIFT, THE FLOOR MUST BE FLAT AND LEVEL. CHECK WITH STRAIGHT EDGE AND LEVEL. IF A FLOOR IS OF QUESTIONABLE SLOPE, CONSIDER A SURVEY OF THE SITE AND/OR THE POSSIBILITY OF POURING A NEW LEVEL CONCRETE SLAB.**



**IMPORTANT: NEW CONCRETE MUST BE ADEQUATELY CURED AT LEAST 30 DAYS MINIMUM. NO LIABILITY FOR ANY DAMAGES WILL BE ACCEPTED SHOULD YOU INSTALL THE LIFT ON AN UNSUITABLE FLOOR.**

### **4.3 IMPORTANT CONCRETE AND ANCHORING INFORMATION**

1. Concrete shall have compression strength of at least 3,000 PSI and a minimum thickness of 4". Measure the length of the supplied anchor bolts in order to achieve a minimum anchor embedment of 3-1/4". If the top of the anchor exceeds 2" above the floor grade, you DO NOT have enough embedment.

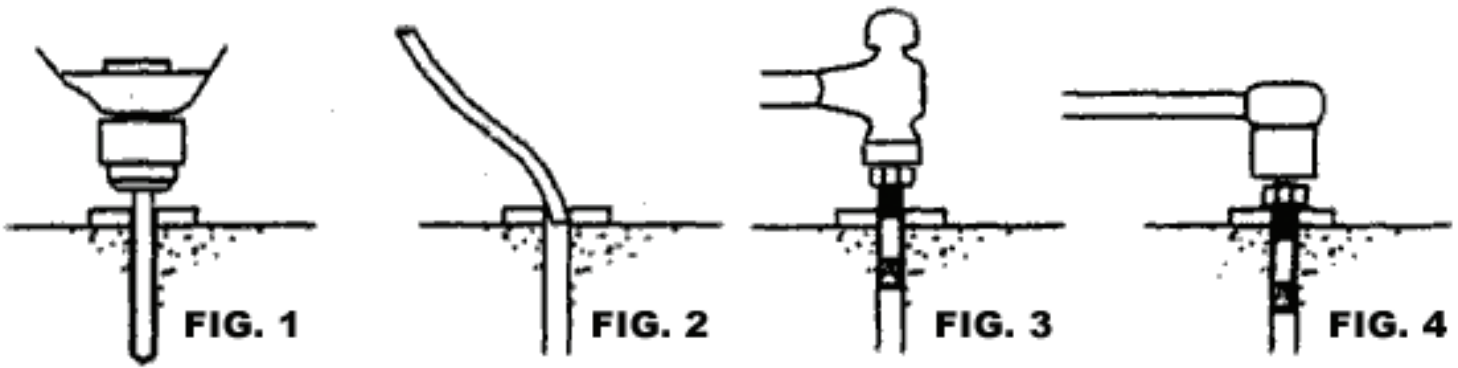
2. Before drilling 3/4" diameter holes in concrete floor using holes in column base plate as guide, make sure the hole distance from the edge of slab is not less than 6". Hole to hole spacing should not be less than 6 1/2 in any direction. Concrete thickness should be a minimum of 4"



3. **DANGER:** DO NOT Install on asphalt or other similar unstable surface. Columns are supported only by anchoring in floor.

4. Shim each column base until each column is plumb. If one column has to be elevated to match the plane of the other column, full size base shim plates should be used. Torque anchors to 85 ft-lbs. Shim thickness MUST NOT exceed 1/2". Adjust the column extensions plumb.

5. If anchors do not tighten to 85 ft-lbs. installation torque, replace concrete under each column base with a 4' x 4' x 6" thick 3,000 PSI minimum concrete pad keyed under and flush with the top of existing floor. Let concrete cure at least 30 days before installing lifts and anchors.



#### 4.4 ANCHORING TIP SHEET

1. Use a concrete hammer drill with a carbide tip, solid drill bit the same diameter as the anchor, 3/4". (.775 to .787 inches diameter). **Do not use excessively worn bits or bits which have been incorrectly sharpened.**
2. Keep the drill perpendicular to the concrete while drilling.
3. Let the drill do the work. Do not apply excessive pressure. Lift the drill up and down occasionally to remove residue to reduce binding.
4. Drill the hole for anchor bolt completely through the concrete. If an error is made during the installation of these anchors, this will allow for the anchor bolt to be driven down into the ground, so that a new anchor may be installed in place (fig.1).
5. **Be sure to clean all dust from hole.** (fig. 2).
6. Place a flat washer and hex nut over threaded end of anchor, leaving approximately 1/4 inch of thread exposed above the nut (fig.3). Carefully tap anchor into the concrete until nut and flat washer are against base plate. Be sure to only tap the top of the anchor and not the nut. This could cause damage to the threads of the anchor.
7. Tighten the nut (fig. 4) to **80 ft-lbs** of torque (typically this should only be two to three full turns).



**DO NOT USE AN IMPACT WRENCH TO TIGHTEN ANCHORS!**

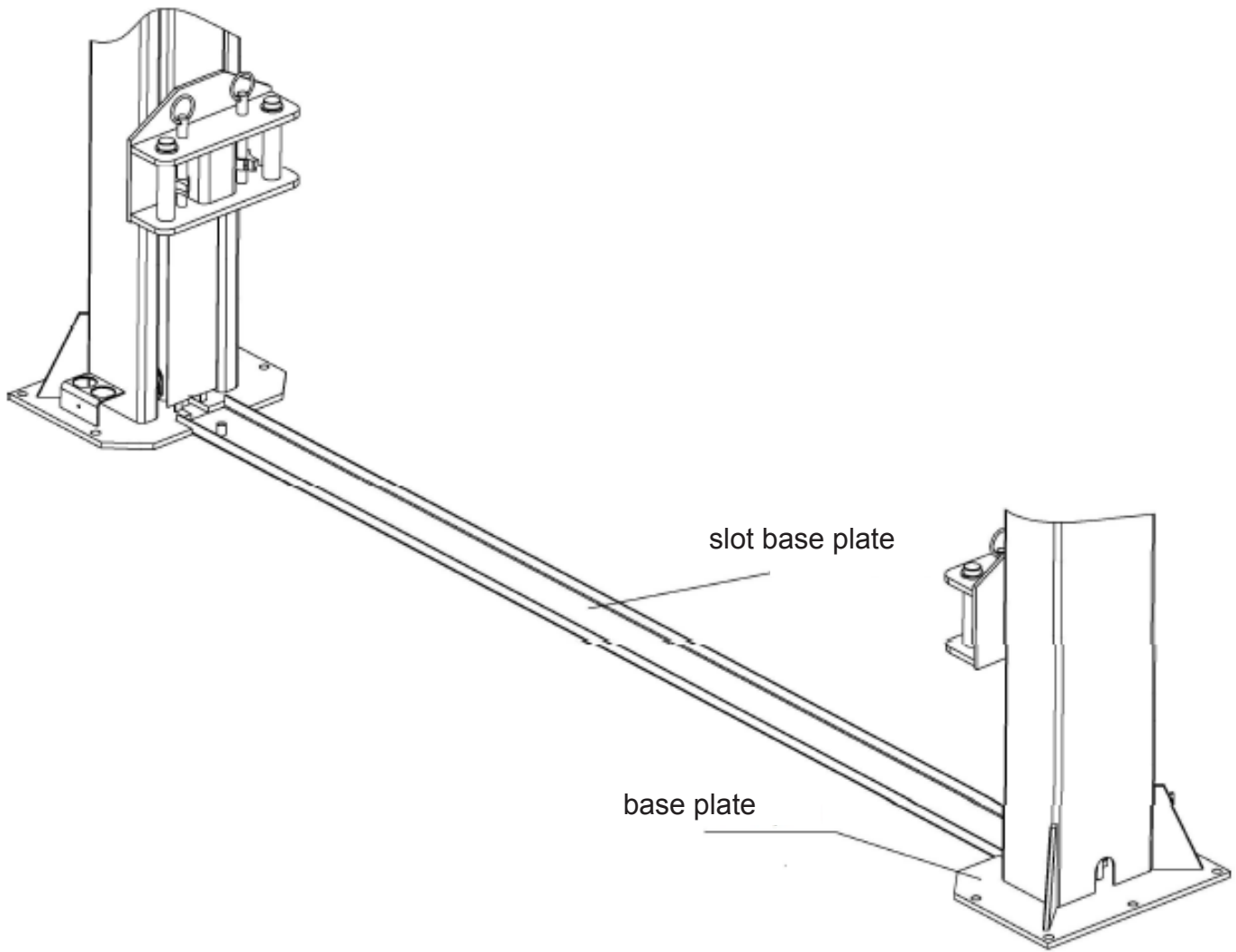
# 5. INSTALLATION INSTRUCTIONS

**PLEASE READ THESE INSTRUCTIONS BEFORE STARTING TO OPERATE THE LIFT.**

- STEP 1: After unloading the lift, place it near the intended installation location.
- STEP 2: Remove the shipping bands and packing materials from the unit.
- STEP 3: Remove the packing brackets and bolts holding the two columns together (do not discard bolts, they are used in the assembly of the lift)
- STEP 4: Once the lift location is decided, chalk the center line in the bay and ensure that the proper lift placement is observed from walls and obstacles. Also check the ceiling height for clearance in this location. **NOTE:** the power unit column can be located on either side.
- STEP 5: Raise the columns to a vertical position. Position the columns facing each other 134 5/8" outside base plates. **NOTE:** The power unit column is referred to as the main side column and the non power unit column is referred to as the **offside column**.
- STEP 6: Using a 3/4" concrete drill bit, drill the anchor holes in the main side column, installing anchors as you go. Use a block of wood or rubber mallet to drive anchor bolts in. (Fig C.)



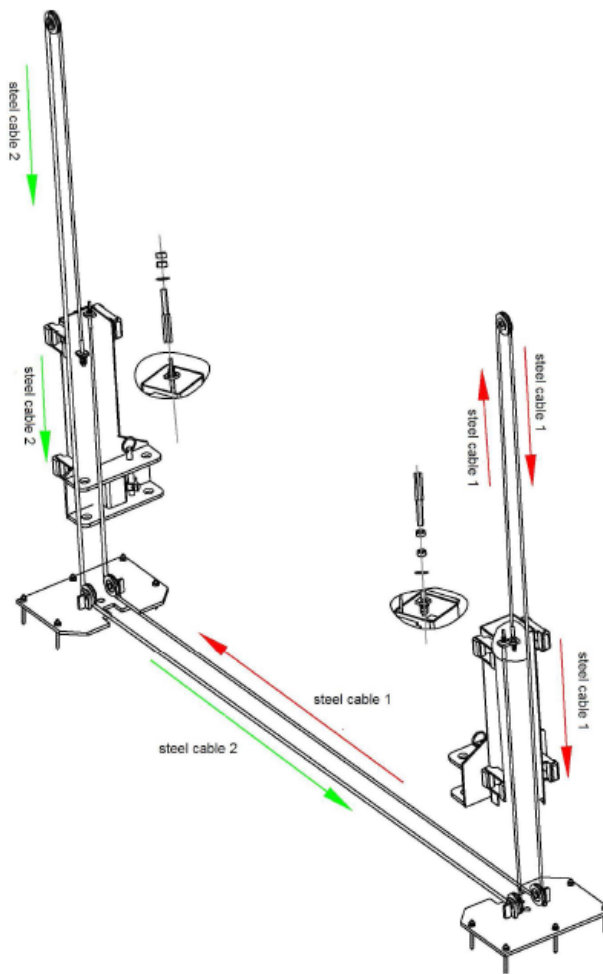
- STEP 7: Using a level, check column for side-to-side plumb and front-to-back plumb. Use 3/4" washers or shim stock, placing shims as close as possible to the hole locations. This will prevent bending the column bottom plates. Tighten 3/4" anchor bolts to 85-lbs. **NOTE:** Do not use impact wrench.
- STEP 8: Using a tape measure, measure from back corner of the base on main side column to the opposite back corner of the offside column to ensure columns are square. After confirming the dimensions, install the slot base plate (Fig D) to the bottom of the columns **BEFORE** drilling the anchors for the offside column to ensure the column is plumb.



STEP 9: After the slot box plate is installed, drill and anchor offside column as described in steps 6 & 7.

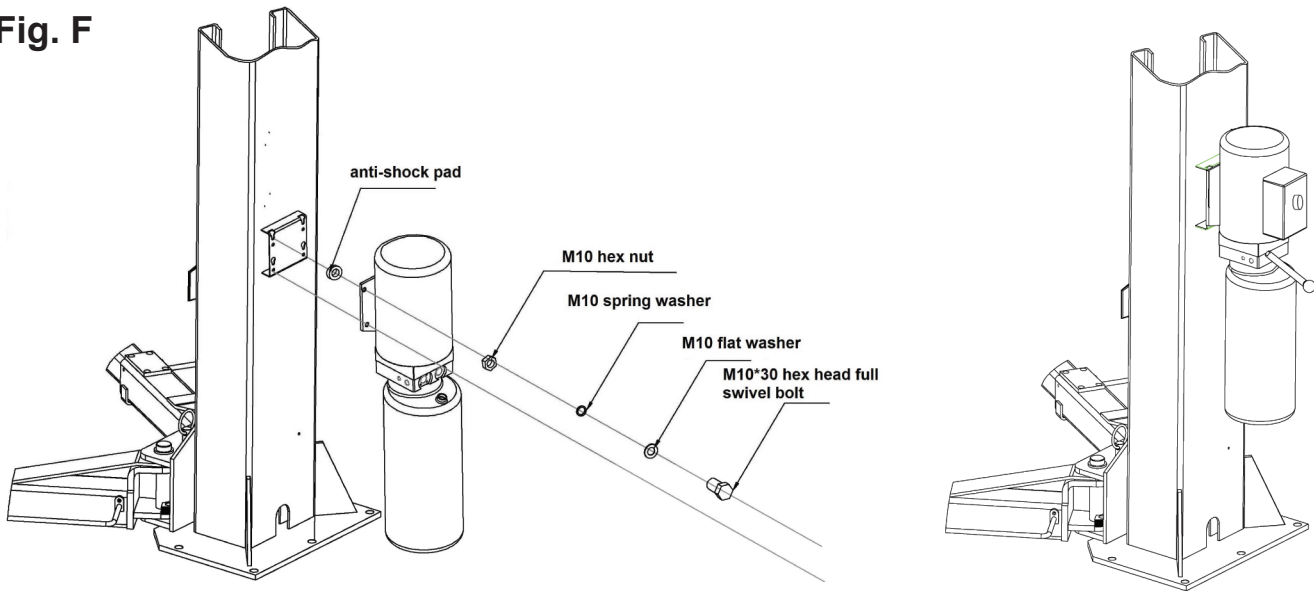
STEP 10: Installing the equalizing cables: refer to Fig E for cable routing. Set carriages on the first safety latch engagement. Be sure each carriage is at the same height by measuring from the top of the base to the bottom of the carriage (double check the latches before working under the carriages). This dimension should be within 1/4". Run first cable and tighten nut on one cable stud so that the end of stud passes the nylon on the nut. Pull the other end of cable and run nut on it. Tighten both nuts. Repeat above for second cable.

**Fig. E**



STEP 11: Mount the power unit on lift as shown in Fig. F.

**Fig. F**



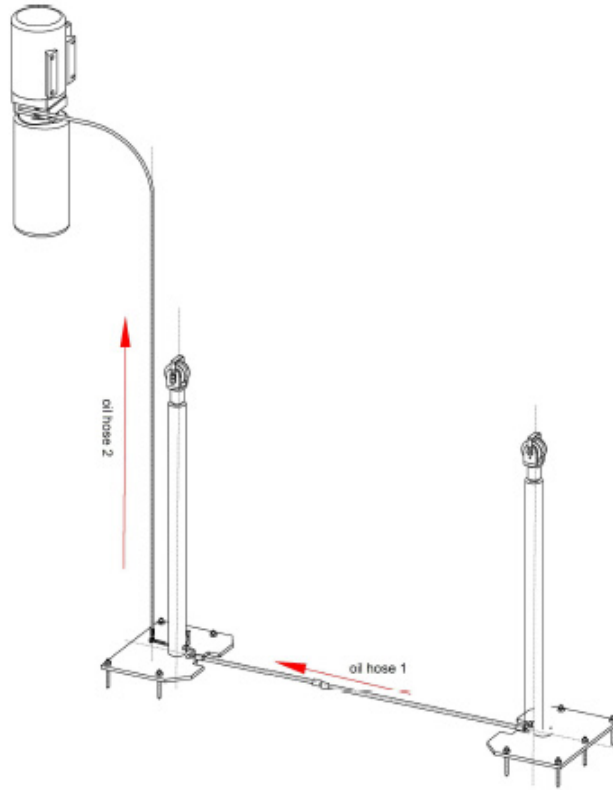
**Connect oil hoses.**

1. Make sure all hose connectors are clean.
2. Connect the oil hose as per the following diagram.



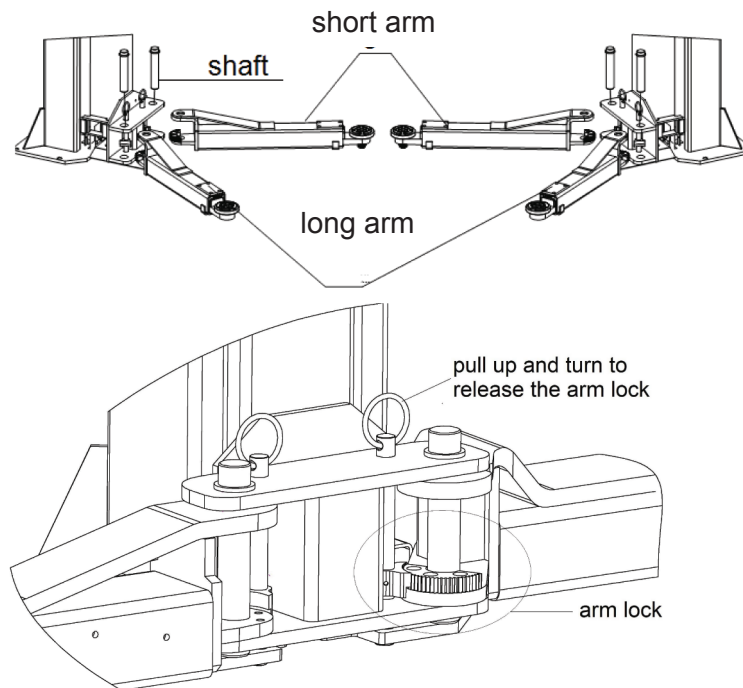
STEP 12: Connecting the hydraulic hoses, as shown on Fig G

**Fig. G**



STEP 13: Install the swing arms on the carriages (Fig H) using the included 1 1/2" diameter pins. Check for proper engagement of the arm lock- the rack on the lock should fully engage the gear on the arm.

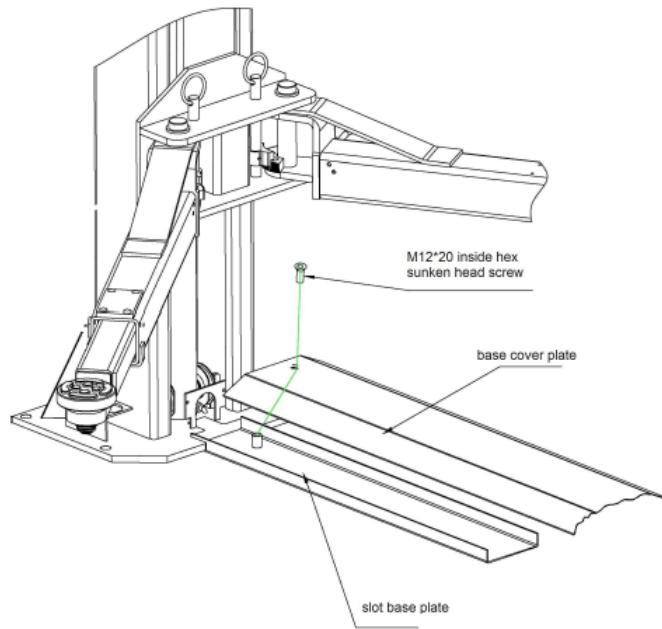
**Fig. H**



STEP 14: Adjust the tension of the carriage cables. Adjust each cable to approximately 1/2" side-to-side play. Check the latch releases to insure the carriage is still sitting on the appropriate latch.

## STEP 15: Mount the Floor plate base cover as shown in figure #1

**Fig. #1**



STEP 16: Remove the fill cap from the power unit and fill the oil tank reservoir. To fill the oil tank reservoir, the lift must be completely lowered. Fill the oil tank with a premium quality ISO-32, or AW-46 Hydraulic Oil, or premium quality ATF-DEXRON-III / MERCON.

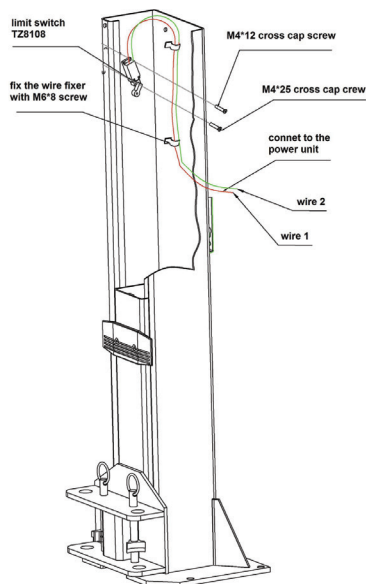
STEP 17: Make the Electrical hookup to the power unit.(220V Single Phase). It is recommended that a 220 Volt, 30 Amp twist lock plug be installed in the power line just ahead of the power unit. Size wire for 30-amp circuit.



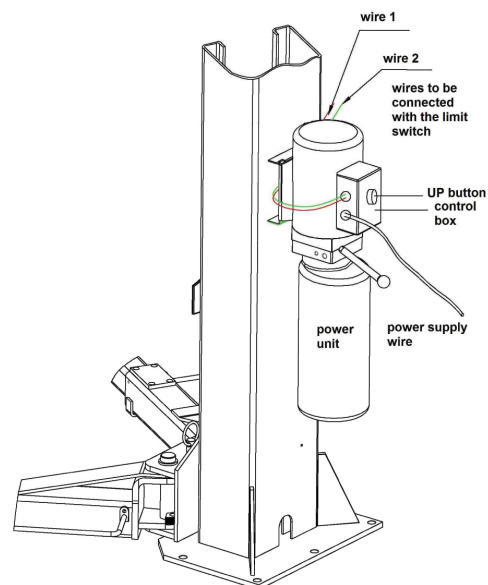
**WARNING:** The wiring must comply with local code. Have a certified licensed electrician make the electrical hook-up to the power unit. Protect each circuit with time delay fuse or circuit breaker 208v.230v single Phase. 60Hz 30 Amp.

STEP 18: Install the limit switch. Fig I & J.

**Fig. I**

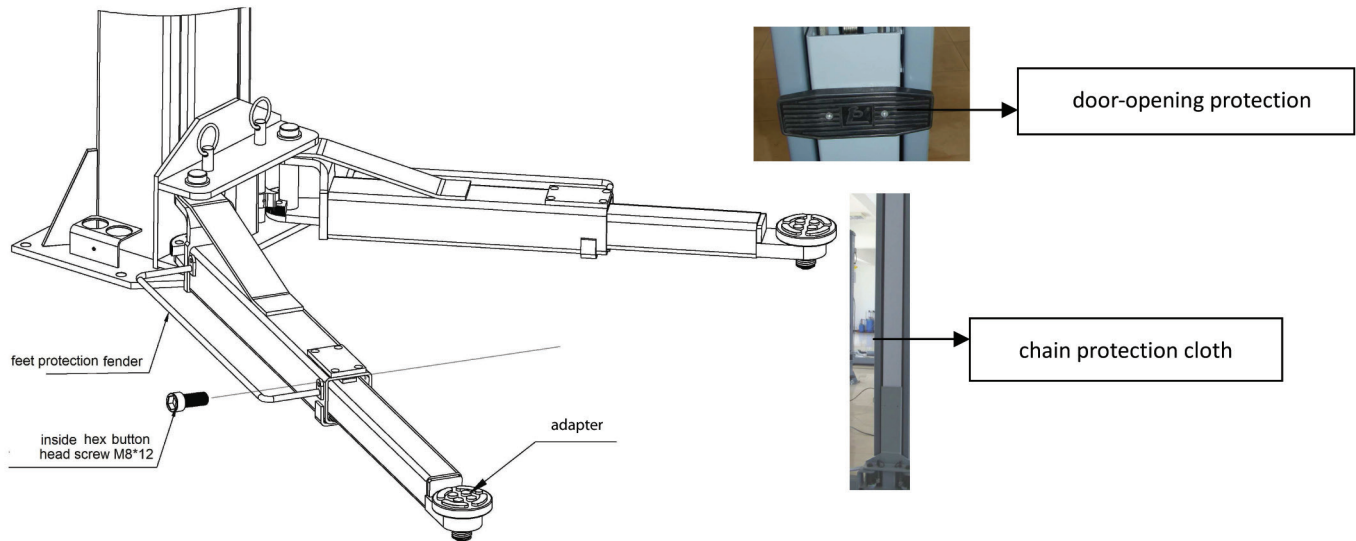


**Fig. J**



STEP 19: Install foot protection fenders, chain protection panels, door-protection bumpers and lifting adapters. Fig Q.

Fig. K



STEP 20: Do not place any vehicle on the lift at this time. Read the operation instructions (pg 18-20) and cycle the lift up and down several times to ensure safety latches click together and all air is removed from the system. Ensure all hydraulic fittings are tight and not leaking. To lower the lift, the safety latch releases must be manually released. Latches will automatically reset once the lift ascends approximately 17” from base. If latches click out of sync, tighten the cable on the one that clicks first.

**WARNING: DO NOT PERFORM ANY MAINTENANCE OR INSTALLATION OF ANY COMPONENTS WITHOUT FIRST ENSURING THAT ELECTRICAL POWER HAS BEEN DISCONNECTED AT THE SOURCE OR PANEL AND CANNOT BE REENERGIZED UNTIL ALL MAINTENANCE AND/OR INSTALLATION PROCEDURES ARE COMPLETED.**

**DANGER: DO NOT RUN POWER UNIT WITHOUT FLUID. DAMAGE TO PUMP CAN OCCUR. THE POWER UNIT MUST BE KEPT DRY. DAMAGE TO POWER UNIT CAUSED BY WATER OR OTHER LIQUIDS SUCH AS DETERGENTS, ACID ETC., IS NOT COVERED UNDER WARRANTY.**

### ITEMS TO BE CHECKED AFTER INSTALLATION

S/N	Check items	YES	NO
1	Are the posts perpendicular to the floor?		
2	Are the two posts paralleled?		
3	Are oil hoses installed correctly?		
4	Are steel cable installed correctly?		
5	Are all lifting arms installed correctly?		
6	Are all electrical components properly connected?		
7	Are all items requiring lubrication properly greased?		

# 6. OPERATION INSTRUCTIONS



**WARNING: LIFT OPERATION BY TRAINED AUTHORIZED PERSONNEL OVER 18 YEARS ONLY. APPLY THE PARKING BRAKE AFTER POSITIONING THE VEHICLE ON THE LIFT. DO NOT ALLOW ANYONE TO STAY IN LIFT AREA DURING RAISING AND LOWERING CYCLES. CLOSELY WATCH THE VEHICLE AND THE LIFT DURING RAISING AND LOWERING CYCLES. OBSERVE THE RATED LOAD CAPACITY AND LOAD DISTRIBUTION. DO NOT ALLOW ANYONE TO CLIMB ON LIFT OR STAY INSIDE VEHICLE. AFTER RAISING THE VEHICLE FRAME 6”, STOP AND CHECK ADAPTERS FOR SECURE CONTACT. PERFORM BUMPER TEST(PG.2). MAKE SURE THE VEHICLE DOORS ARE CLOSED DURING RAISING AND LOWERING CYCLES.**

## **6.1 DEFECTS / MALFUNCTIONS**



**WARNING: IN CASE OF DEFECTS OR MALFUNCTIONS SUCH AS JERKY LIFT MOVEMENT OR DEFORMATION OF THE SUPERSTRUCTURE, SUPPORT OR LOWER THE LIFT IMMEDIATELY. CONTACT QUALIFIED SERVICE PERSONNEL.**

## **6.2 CONTROLS**

### **6.2.1 UP CONTROL**



Once the up button is actuated, the lift moves up until the button is released or the limit stop is reached.


### **6.2.2 SAFETY LOCK CONTROL**

The safety latch mechanism will “Trip Over” as the lift raises and drop into each safety latch stop. To lock the lift you must press the lowering handle on the power unit (Fig. R) to relieve the hydraulic pressure and let the safety locks engage into a level locked position.



**Fig. R**

 **WARNING: PAY CLOSE ATTENTION WHEN SETTING THE LOCKS. THE LOCKS MUST BE A LEVEL MATCH SET IN ORDER TO AVOID A VEHICLE TILT.**

 **WARNING: ALWAYS LOCK THE LIFT BEFORE GOING UNDER THE VEHICLE. NEVER ALLOW ANYONE TO GO UNDER THE LIFT WHEN RAISING OR LOWERING.**

 **NOTE: It is normal for an empty lift to lower slowly - it may be necessary to add weight.**

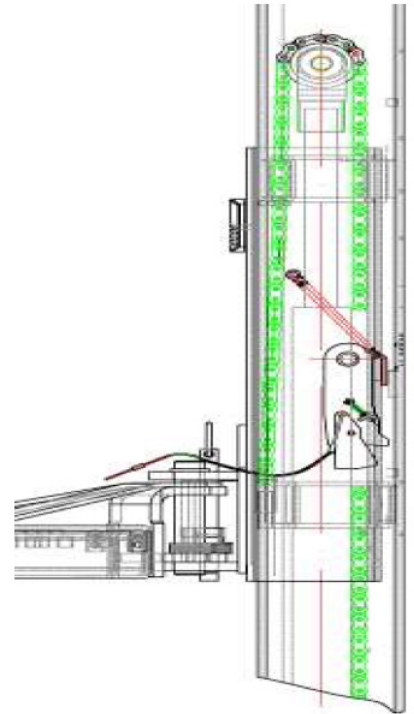
### 6.2.3 LOWERING CONTROL

Press the up button enough to allow the safety locks to be disengaged. Pull both latch releases to release the safety locks. Make sure both sides have been released before lowering lift or you will have to disengage the safety locks again. Press the lowering handle until the lift is completely lowered.

### 6.3 OPERATION

 **WARNING: FAILURE TO OPERATE THE LIFT ACCORDING TO THIS MANUAL MAY CAUSE DAMAGE TO THE LIFT, PROPERTY DAMAGE AND/OR PERSONAL INJURY.**

1. Before driving a vehicle into position, make sure the lift is fully lowered and arms are positioned where they are not in the drive path. Do not hit or run over the lifting arms, as this could damage the vehicle and/or lift. Make sure the lift is fully lowered before moving the vehicle. **NOTE:** It is recommended to swing both arms outward pointing toward the front of the lift prior to loading a vehicle into the 9000AFE.
2. Drive the vehicle between the columns while keeping the vehicle parallel with the lift and aligning the center of gravity of the vehicle with the center of the lift. **NOTE:** The “Center of Gravity” (COG) of the vehicle is the balance point at which there is equal weight in front of and behind the COG, and equal weight on both sides of the COG. The COG is not necessarily the dimensional center of the vehicle, but is often slightly toward the engine from the dimensional center of the vehicle.
3. Turn off the vehicle’s engine and engage the parking brake of the vehicle.
4. Read the vehicles owner’s manual to identify the recommended vehicle lifting points.
5. Prepare the work area according to this manual. Move the lifting arms inward, and position the rubber pads to contact with the vehicle manufacturer’s recommended lifting points.




**Fig. L**

 **IMPORTANT: PLACE THE FOUR RUBBER PADS UNDER EDGE OF VEHICLE AT THE FOUR JACK POINTS.**

6. Once the lifting arms have been positioned under the vehicle lifting points, operate the

power switch to make contact and lift the vehicle slightly. Test to make sure the vehicle is well balanced and the contact between the rubber pads and vehicle lifting points are secure by performing the “BUMPER TEST.” (pg. 2) Then proceed to lift the vehicle to the desired height.

7.  **WARNING:** Do not lift the vehicle if you cannot establish secure and level lifting points. Do not use sub-standard shims or other devices in place of approved and recommended rubber pad adapters. Never use the lift without the rubber pads in place on each plate and in contact with the lifting points of a vehicle.
8. Press up button and raise vehicle to desired height. **Do not go under vehicle until load rests on level safety locks.**
10. While lifting the vehicle a clicking sound should be noticeable which indicates the safety mechanism is operating. If this sound is not heard, immediately cease using the lift and call an authorized service agent.
9. When lift reaches maximum height, a limit switch will come into operation and stop the lift. When lift has stopped, press and hold the lowering handle (Fig. R) until load rests on level safety locks.
11. Once the repair work to the vehicle is complete, make sure to remove all tools, safety jack stands, and materials from under the vehicle and lift. Also, make sure the work area is clear and it is safe to lower the vehicle.
12. Lower vehicle by pressing the Up button to disengage the safety locks. Pull and hold the safety lock handle (Fig. S) to release the safety locks then press the lowering handle (Fig. R) until the lift is completely lowered.
13. Move the lifting arms outward, out of the path of the vehicle. Clear all bystanders, and any objects from work area and direction of vehicle.
14. Disengage the vehicle parking brake. Start the vehicle’s engine, and drive the vehicle off the lift slowly and carefully.

 **WARNING: THE OPERATOR MUST BE TRAINED AND AUTHORIZED TO OPERATE THE LIFT.**

 **WARNING: DO NOT GO UNDER VEHICLE UNDER ANY CIRCUMSTANCES WHILE VEHICLE IS BEING RAISED OR LOWERED.**

 **WARNING: LOAD MUST BE EVENLY DISTRIBUTED BETWEEN BOTH LIFTING PLATFORMS. IF LOAD IS UNBALANCED, REPOSITION VEHICLE. DO NOT LOWER ON TO LOCKS AT DIFFERENT HEIGHTS.**

# 7. MAINTENANCE



**WARNING: DISCONNECT THE POWER BEFORE SERVICING THE LIFT.**



**IMPORTANT: THE MAINTENANCE INTERVALS INDICATED BELOW APPLY TO AVERAGE WORKSHOP USE. THE LIFT SHOULD BE INSPECTED MORE FREQUENTLY FOR SEVERE USE APPLICATIONS.**

## **7.1 MAINTENANCE SCHEDULE**

It is important to keep the lift clean, dry, and well maintained by establishing a periodic preventive maintenance program to ensure trouble-free operation and long service life.

### **7.1.1 DAILY**

1. Check safety locking mechanism is functioning correctly.
2. Check safety lock audibly and visually while in operation.
3. Check safety latches for free movement and full engagement with rack.
4. Inspect the condition of rubber lifting pads and replace as necessary if worn or torn.
5. Check hydraulic connections, and hoses for leakage.
6. Check cable connections - Bends, cracks - and looseness.
7. Check for frayed cables in both raised and lowered positions.
8. Check snap rings at all rollers and sheaves.
9. Check bolts, nuts, and screws and tighten.
10. Check wiring & switches for damage.
11. Keep base plate free of dirt, grease or any other corrosive substances.
12. Check floor for stress cracks near anchor bolts.
13. Check swing arm restraints.

### **7.1.2 WEEKLY**

1. Check anchor bolts torque to 85 ft-lbs for the 3/4" anchor bolts.  
**NOTE: DO NOT USE IMPACT WRENCH.**
2. Check floor for stress cracks near anchor bolts.
3. Check hydraulic oil level.
4. Check and tighten bolts and nuts, and screws.
5. Check pulley assemblies for free movement or excessive wear on yoke or pulley pin.

### **7.1.3 MONTHLY**

1. Check safety mechanism operation.
2. Check condition of shafts, shaft locks and bushings.
3. Check overall cleanliness.
4. Grease rub/slider blocks

### **7.1.4 BIMONTHLY**

1. Check condition of extensions and lubricate.
2. Check oil leaks from cylinders.
3. Check oil leaks at pipe joints.

### **7.1.5 YEARLY**

Service and safety inspection on the lift must be performed by a competent person. This inspection must be recorded. If the 12 month service and safety inspection is not performed, the warranty is null and void.

1. Grease rub blocks and column surface contacting rub blocks.
2. Check the hydraulic fluid. A good maintenance program makes it mandatory to keep hydraulic fluid clean. Operating temperature, type of service, contamination levels, filtration, and chemical composition of fluid should be considered. If operating in harsh dusty conditions, shorter interval may be required.

***The following items should only be performed by a trained maintenance expert.***

- Replace hydraulic hoses.
- Replace cables and sheaves.
- Replace or rebuild hydraulic cylinders as required.
- Replace or rebuild pumps / motors as required.
- Check hydraulic rod and rod end (threads) for deformation or damage.
- Check cylinder mount for looseness and damage.

Relocating or changing components may cause problems. Each component in the system must be compatible; an undersized or restricted line will cause a drop in pressure. All valve, pump, and hose connections should be sealed and/or capped until just prior to use. Air hoses can be used to clean fittings and other components. However, the air supply must be filtered and dry to prevent contamination. Most important - **cleanliness** - contamination is the most frequent cause of malfunction or failure of hydraulic equipment.



## 7.1.6 EVERY OTHER YEAR

Hydraulic oil should be replaced.



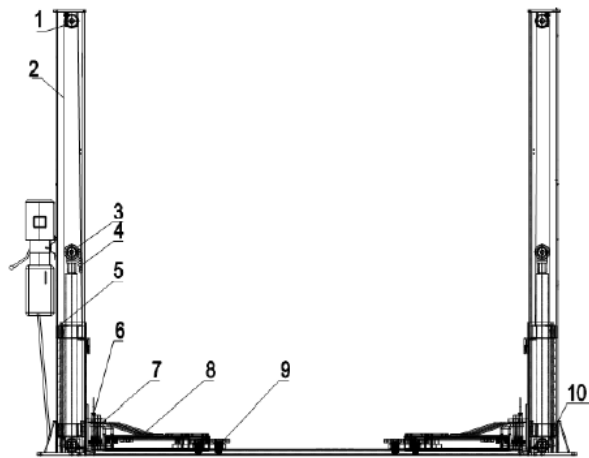
**IMPORTANT: AFTER CLEANING WORKSHOP FLOOR OR LIFT, TO MAINTAIN HOIST EFFICIENCY WE ADVISE TO LUBRICATE LIFTING ARM LOCKING MECHANISM, AND SAFETY LOCKING MECHANISM. CHECK SAFETY LOCKING MECHANISM IS FUNCTIONING CORRECTLY.**

## 7.2 MAINTENANCE BY OPERATOR

1. All moving parts have been lubricated at the factory and should be re-lubricated before the first use and at least once every six months to prevent damage.

The following parts need to be lubricated.

S/N	Name
1	UP pulley
2	Steel cable
3	Chain wheel
4	Chain
5	Slider
6	Shaft
7	Arm lock
8	Lifting arm
9	Lifting tray
10	Down pulley



### 7.2.1 HYDRAULIC SYSTEM (FIG. M)

1. Check the fluid level with the lift fully lowered and add fluid as required. Use premium quality ISO-32, AW-32, or AW-46 hydraulic oil, or premium quality ATF DEXRON-III/MERCON.
2. Visually check all hydraulic hoses and connections for tightness before each use to ensure proper working condition.
3. Lightly oil the cylinder rods at least once every six months or when they become dry.



**Fig. M**

## 7.2.2 GREASING POINTS

Slide Tracks:

The carriage assembly slide tracks should be greased every six months (or more frequently in case of noise generation).

Slightly grease the slide tracks (inside corners of columns) over their whole length using a brush.

## 7.2.3 OPERATION AND WEAR CHECKS.

1. Examine lift for structural cracks, bends, or other signs of damage prior to each use. Do not use this product if worn or damaged.
2. Check that the safety locking mechanism is functioning correctly.
3. Check that the safety lock is audibly and visibly operating correctly.
4. Check the floor for stress cracks near the anchor bolts.

## 7.2.4 LIFT STABILITY

1. Every six months check the nuts of all bolts for correct installation torque.
2. Retighten them as required. **NOTE: DO NOT USE AN IMPACT WRENCH.**

## 7.3 CLEANING



**DANGER: DO NOT USE HIGH PRESSURE / STEAM JET CLEANERS OR CAUSTIC CLEANING AGENTS.**

**RISK OF DAMAGE!**

1. **PERIODICALLY WASH OFF AGGRESSIVE SUBSTANCES AND TREAT THE LIFT WITH OIL OR WAX SPRAY.**
2. **REPAIR THE DAMAGE TO THE PAINTWORK IMMEDIATELY TO PREVENT CORROSION.**

# **8. TROUBLE SHOOTING**

## **1. Motor does not run:**

- A. Breaker or fuse blown.
- B. Motor thermal overload tripped. Wait for overload to cool.
- C. Faulty wiring connections.....Call electrician for service.
- D. Defective up button.....Call electrician for service.
- E. Defective limit switch.....Call electrician for service.

## **2. Motor runs but will not raise:**

- A. A piece of debris is under the check valve. Push release (Fig. R) handle down and push the up button at the same time. Hold for 10-15 seconds. This should flush the system.
- B. Check the clearance between the plunger valve of the lowering handle. There should be 1/16".
- C. Remove the check valve cover and clean ball and seat.
- D. Oil level too low. Oil level should be just under the vent cap port when the lift is in the lowered position.
- E. Motor is wired in reverse.....Call electrician for service.
- F. Loose Oil Hose.....Check connections.

## **3. Oil blows out breather of power unit:**

- A. Oil reservoir overfilled.
- B. Lift lowered too quickly while under a heavy load.
- C. Air was trapped in cylinder (not properly bled.)

## **4. Motor hums and will not run:**

- A. Impeller fan cover is dented. Take off and straighten.
- B. Faulty wiring.....Call electrician.
- C. Bad capacitor.....Call electrician.
- D. Low voltage.....Call electrician.
- E. Lift overloaded.....Reduce weight.

## **5. Lift jerks going up and down: Air in hydraulic system. Raise lift all the way to top and return to floor; Repeat 4-6 times. Do not let this overheat power unit.**

## **6. Oil leaks:**

- A. Check the power unit: If the power unit leaks hydraulic oil around the tank-mounting flange, check the oil level in the tank. The level should be two inches below the flange of the tank. Check with a screwdriver.
- B. Check the rod end of the cylinder: If the rod seal of the cylinder is out, rebuild or replace the cylinder.
- C. Breather end of the cylinder: If the piston seal of the cylinder is out, rebuild or replace the cylinder.

## **7. Lift makes excessive noise:**

- A. Leg of the lift is dry and requires grease.
- B. Cylinder pulley assembly or cable pulley assembly is not moving freely.
- C. May have excessive wear on pulley pins or yoke.
- D. Seals inside of cylinder have dried due to the lack of conditioners that are not found in low grade fluids. (CAT® oil is a solution.)

# 8. TROUBLE SHOOTING

## **8. Lowering too slow:**

- A. Hydraulic oil is dirty.....Replace the oil.
- B. The oil hose is clogged or damaged.....Clean or replace.
- C. The throttle valve is jammed.....Clean or replace.

## **9. Raising too slow:**

- A. The oil filter is dirty.....Clean or replace.
- B. Oil level is too low.....Add oil.
- C. Damaged cylinder seal.....Replace seal.

## **9. OWNER/EMPLOYER RESPONSIBILITIES**

The owner/employer:

Shall establish procedures to periodically maintain, inspect and care for the lift in accordance with the manufacturers recommended procedures to ensure its continued safe operation.

Shall provide necessary lockout / tag outs of energy sources per ANSI Z244.1 - 1982 before beginning any lift repairs.

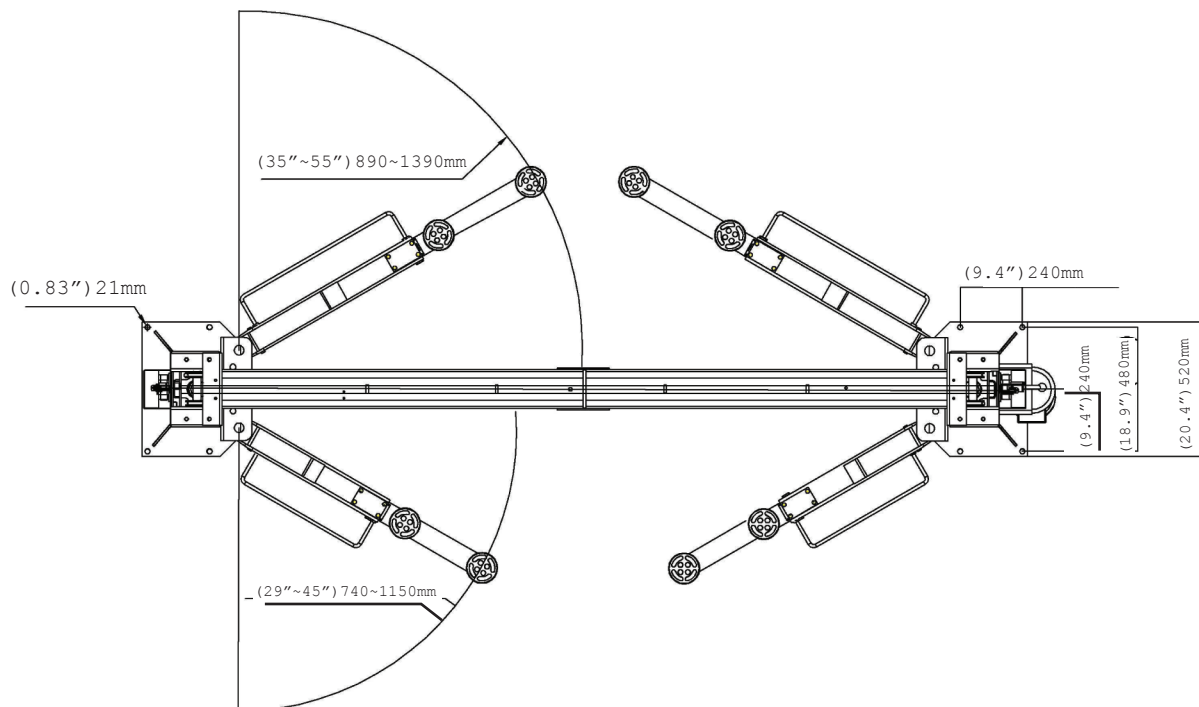
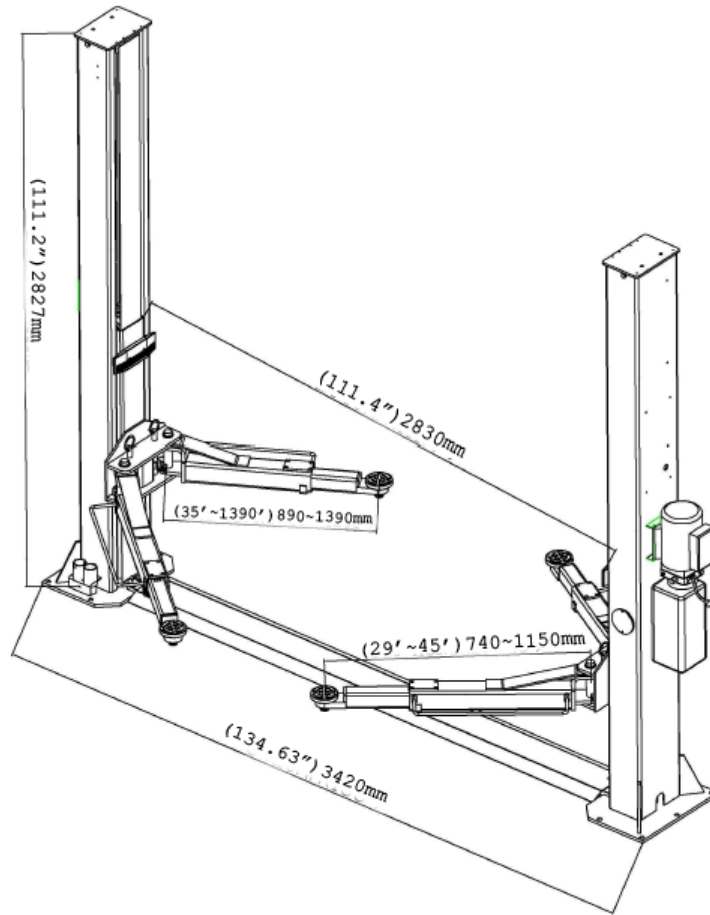
Shall not modify the lift in any manner without prior written consent of the manufacturer.

Shall display this manual or copy supplied with the lift in a conspicuous, dry location in the lift area convenient to the operator.

Shall insure that lift operators are instructed in the safe proper use and operation of the lift using the manufacturer's instructions outlined within this manual supplied with the lift.

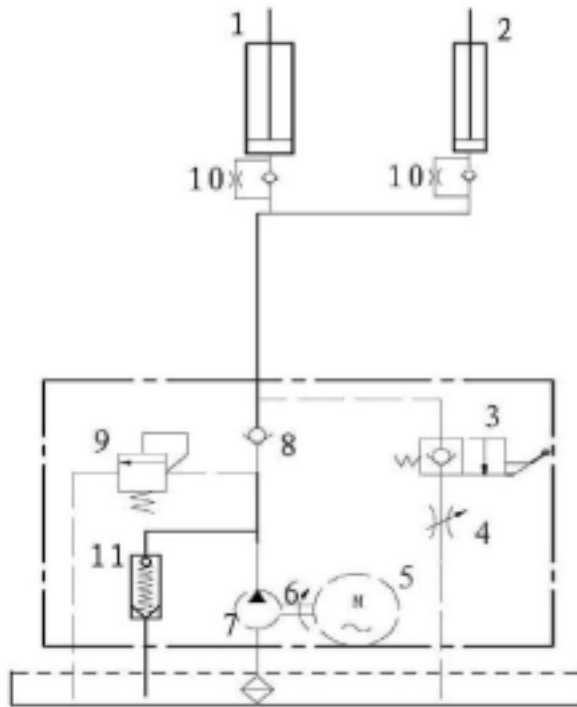
# 10. DIAGRAMS

## FIG. 1 - 9000AFE

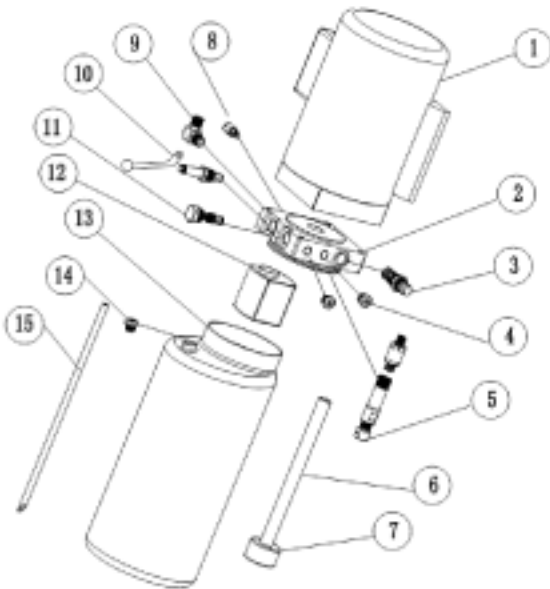


# FIG. 2 - 9000AFE

## Hydraulic working system



1. Main cylinder
2. Assistant cylinder
3. Manual unloading valve
4. Throttle valve
5. Motor
6. Coupling
7. Gear pump
8. Single-way valve
9. Overflow valve
10. Anti-surge valve
11. Cushion valve

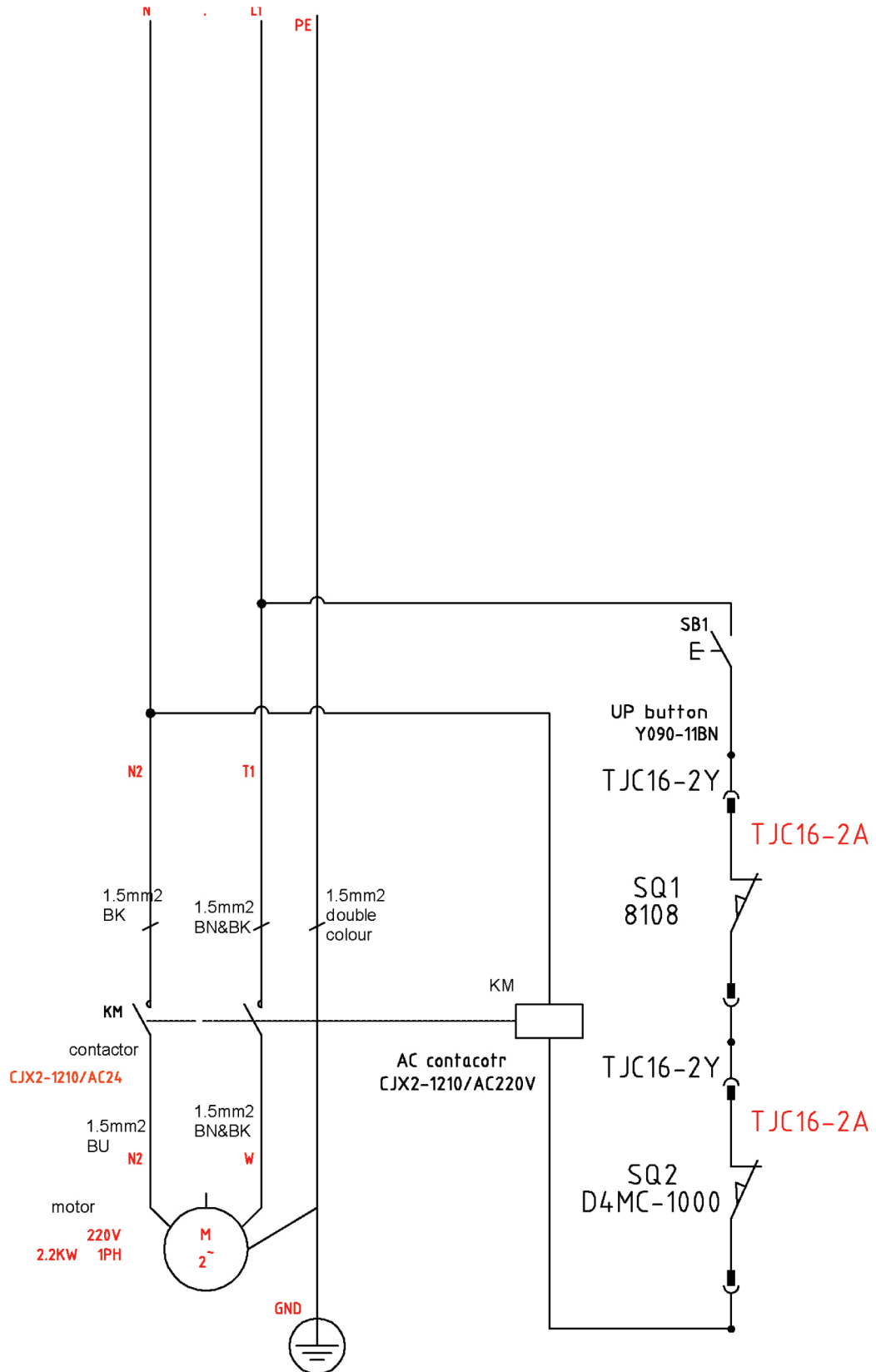


S/N	Description	QTY
1	Motor	1
2	Hydraulic block	1
3	Overflow valve	1
4	Fitting	2
5	Cushion valve	1
6	Absorbing oil pipe	1
7	Oil filter	1
8	Throttle valve	1
9	Oil hose tie-in	1
10	Manual unloading valve	1
11	Check valve	1
12	Gear pump	1
13	Oil tank	1
14	Oil tank cover	1
15	Oil back pipe	1

# FIG. 3 - 9000AFE

## Wiring diagram

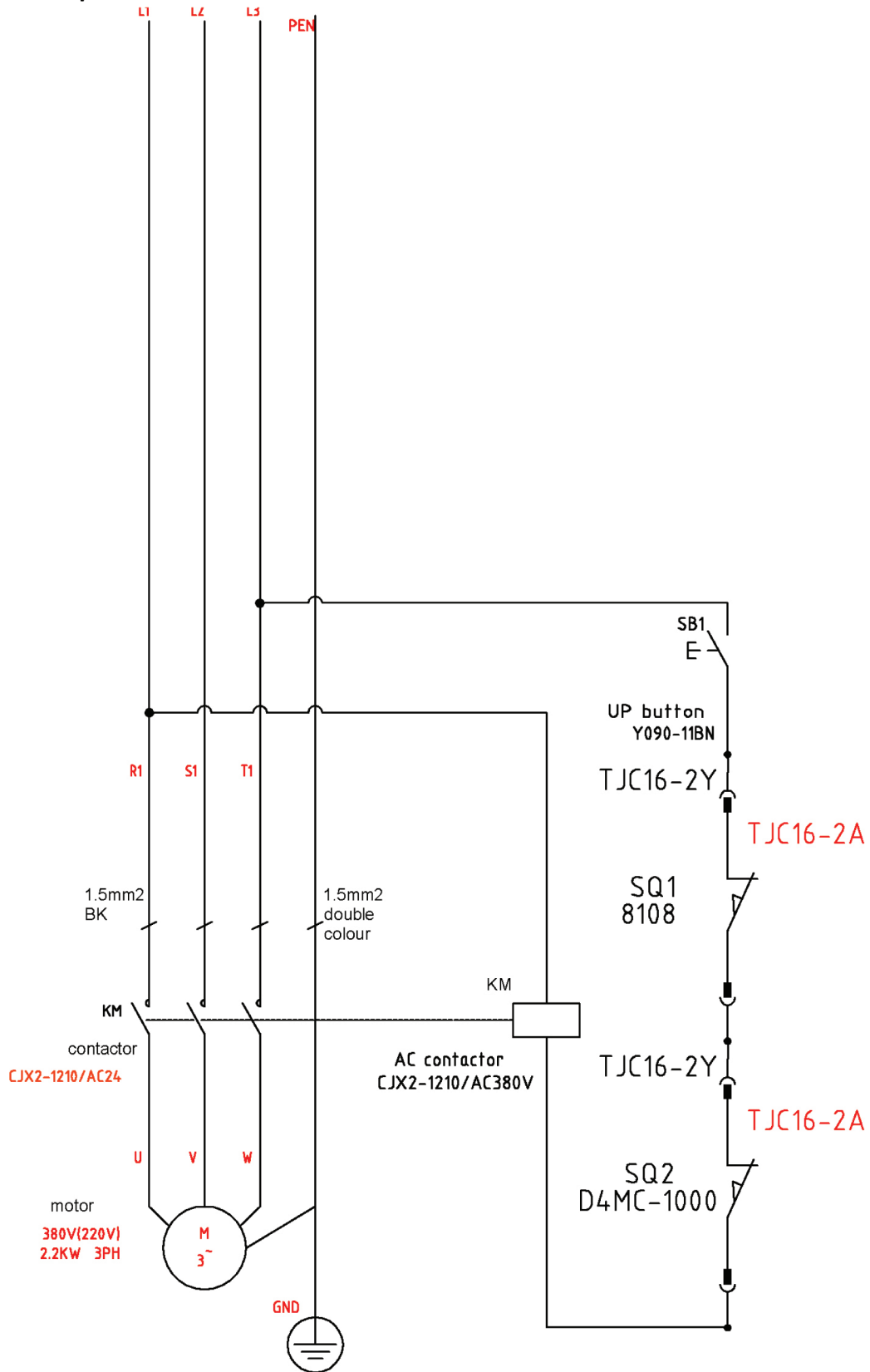
### Single phase



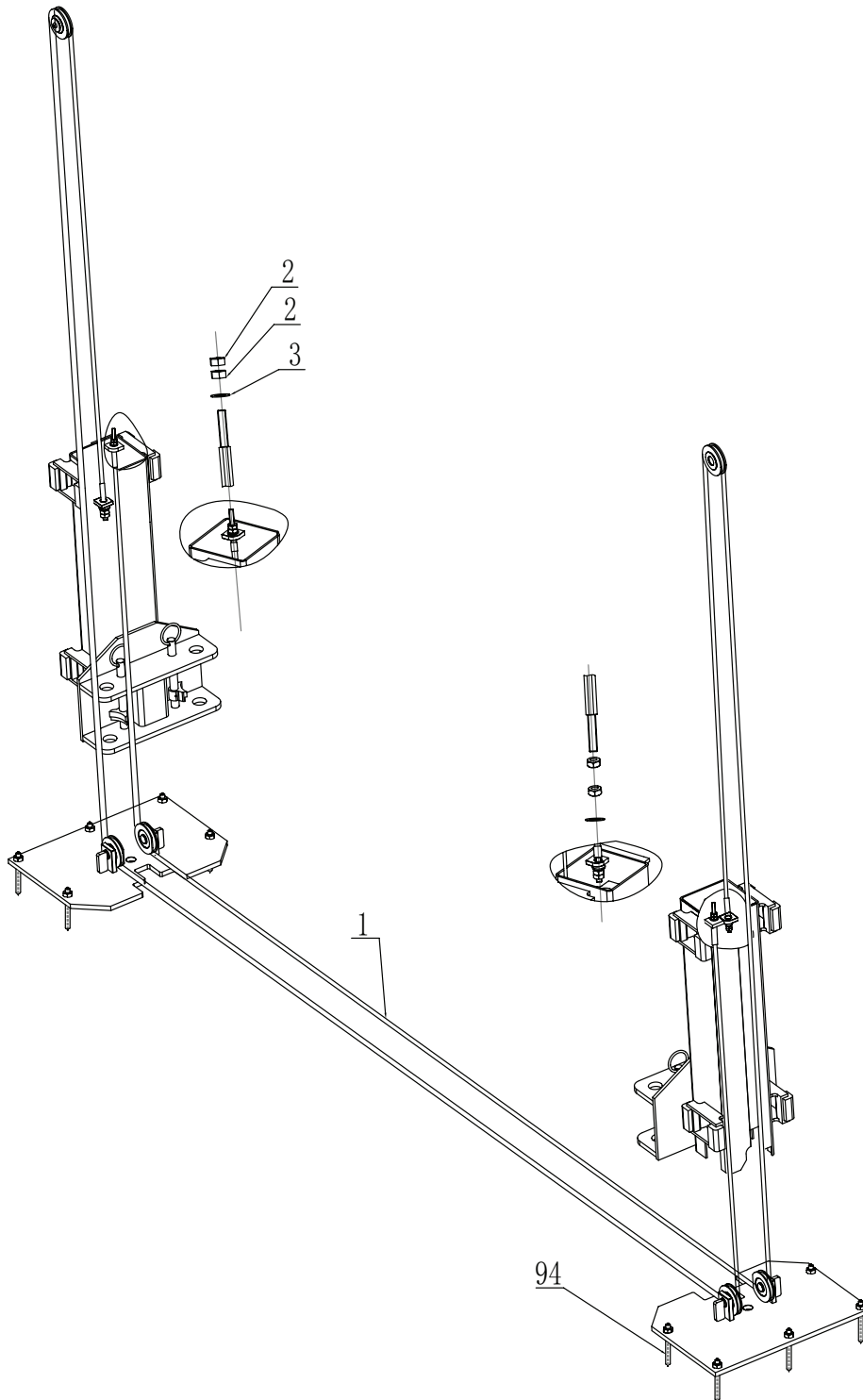


# FIG. 4 - 9000AFE

Three phase

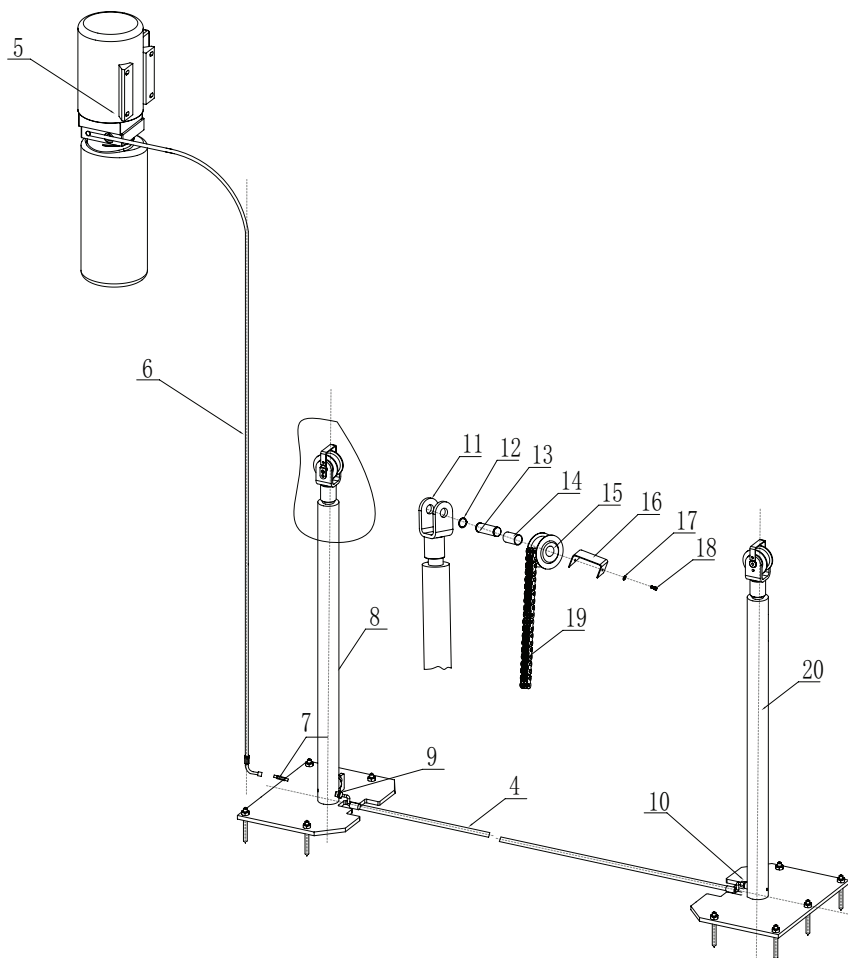


# FIG. 5 - 9000AFE



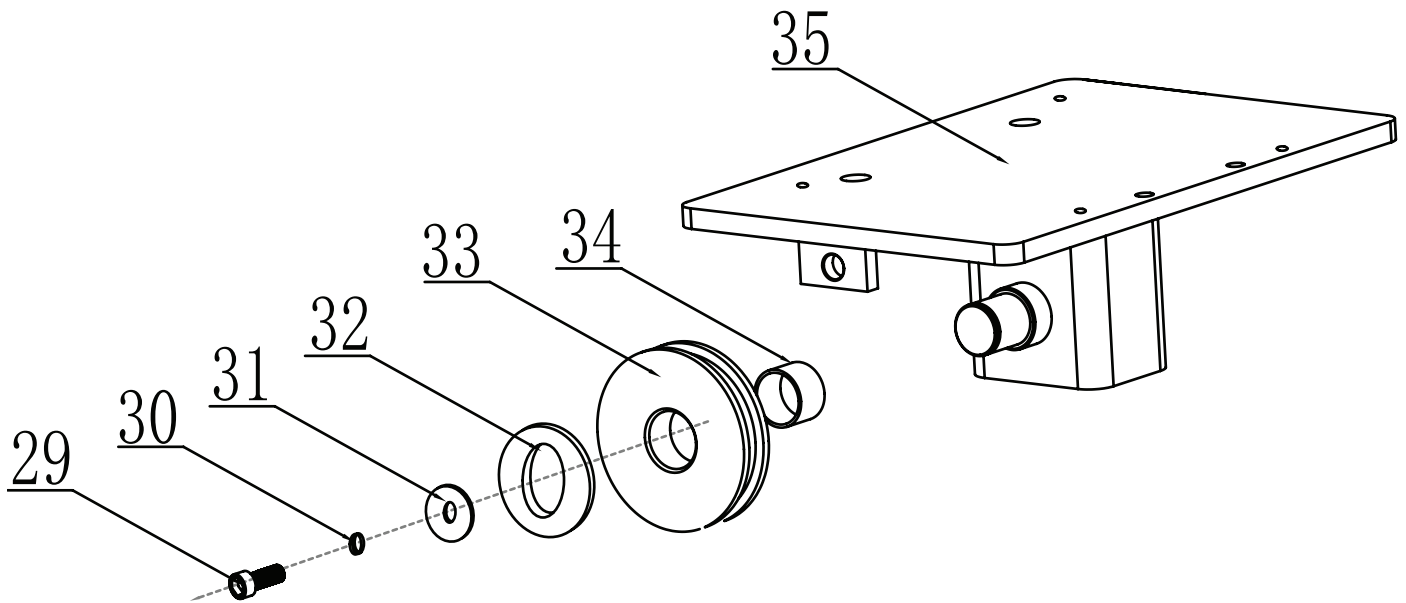
S/N	Material #	Name	Drawing #	Qty	Property	Note
1	615001010	Steel cable L=8785mm	6254-A6	2	Assembly	203101008
2	203101009	Hex nut M16	GB/T610-2000	8	Standard	
3	204101009	Flat washer M16	GB/T95-1985	4	Standard	
94	201201007	Expansion bolts M18*160		10	Standard	

# FIG. 6 - 9000AFE



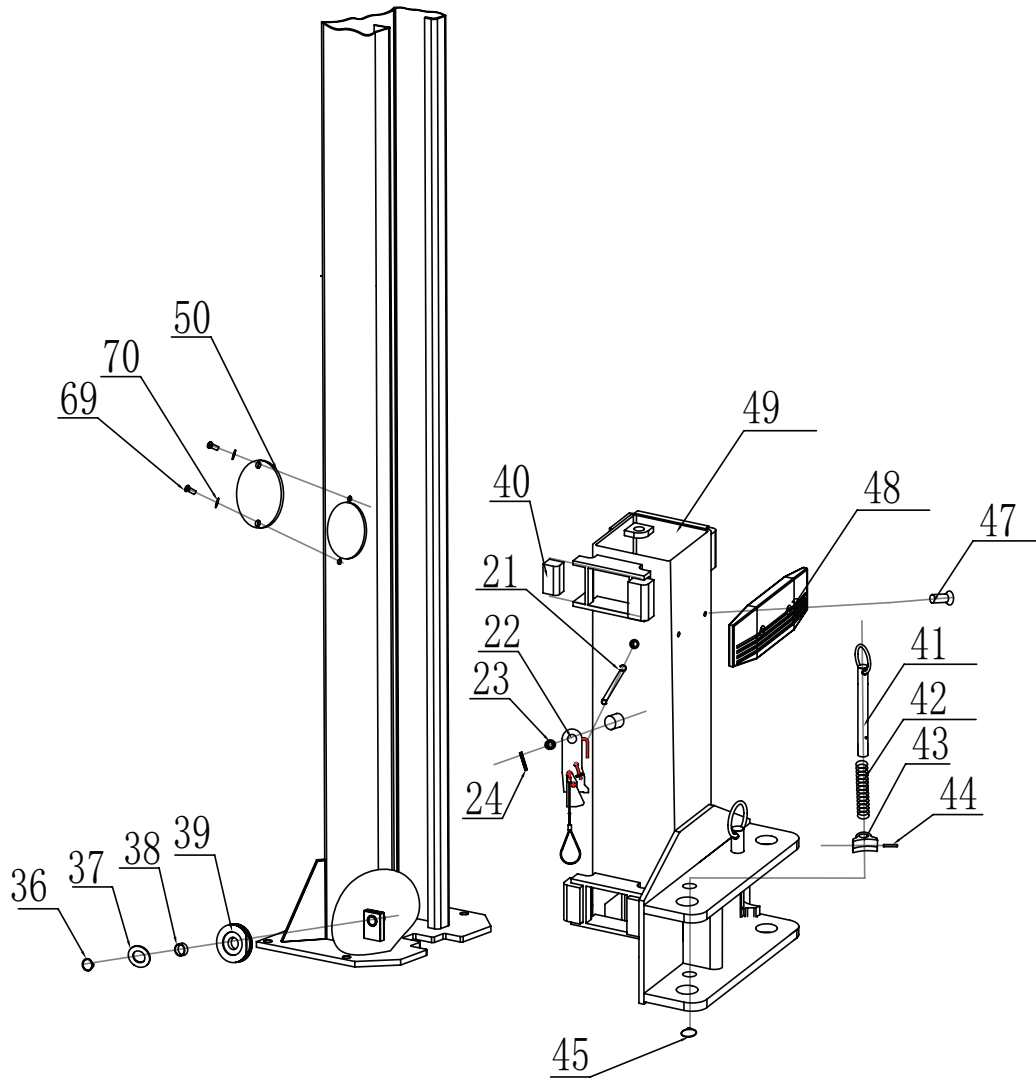
S/N	Material #	Name	Drawing #	Qty	Property	Note
4	624001025	Rubber oil hose L=2280		1	Assembly	
5		Power unit (USA-motor)	EE-40D	1	Assembly	
6	624001024	Rubber oil hose L=1300		1	Assembly	
7	615001005	Long connector		2	Assembly	
8	615001007	Drive oil cylinder	6254E-A4-B6	1	Assembly	
9	615001009	Connector	6254E-A4-B11	1	Zinc-plating	
10	615001008	Short connector	6254E-A4-B10	1	Zinc-plating	
11	612001001	Chain wheel bracket	6254E-A4-B2	2	Zinc-plating	
12	204301009	Circlip 25	GB/T894.2-1986	4	Standard	
13	410010101	Shaft of chain wheel	6254E-A4-B3	2	Zinc-plating	
14	205101013	Bearing 2548	SF-1	2	Standard	
15	410010111	Chain wheel	6254E-A4-B4	2	Zinc-plating	
16	410010121	Retaining plate	6254E-A4-B7	2	Zinc-plating	
17	204201003	Spring washer M6	GB/T93-1987	4	Standard	
18	202109018	Inside hex cylinder head screw	GB/T70.1-2000	4	Standard	
19	208108001	Chain	LH1234-127LGB/6074-1995	2	Standard	
20	615001006	Oil cylinder	6254E-A4-B5	1	Assembly	

# **FIG. 7 - 9000AFE**



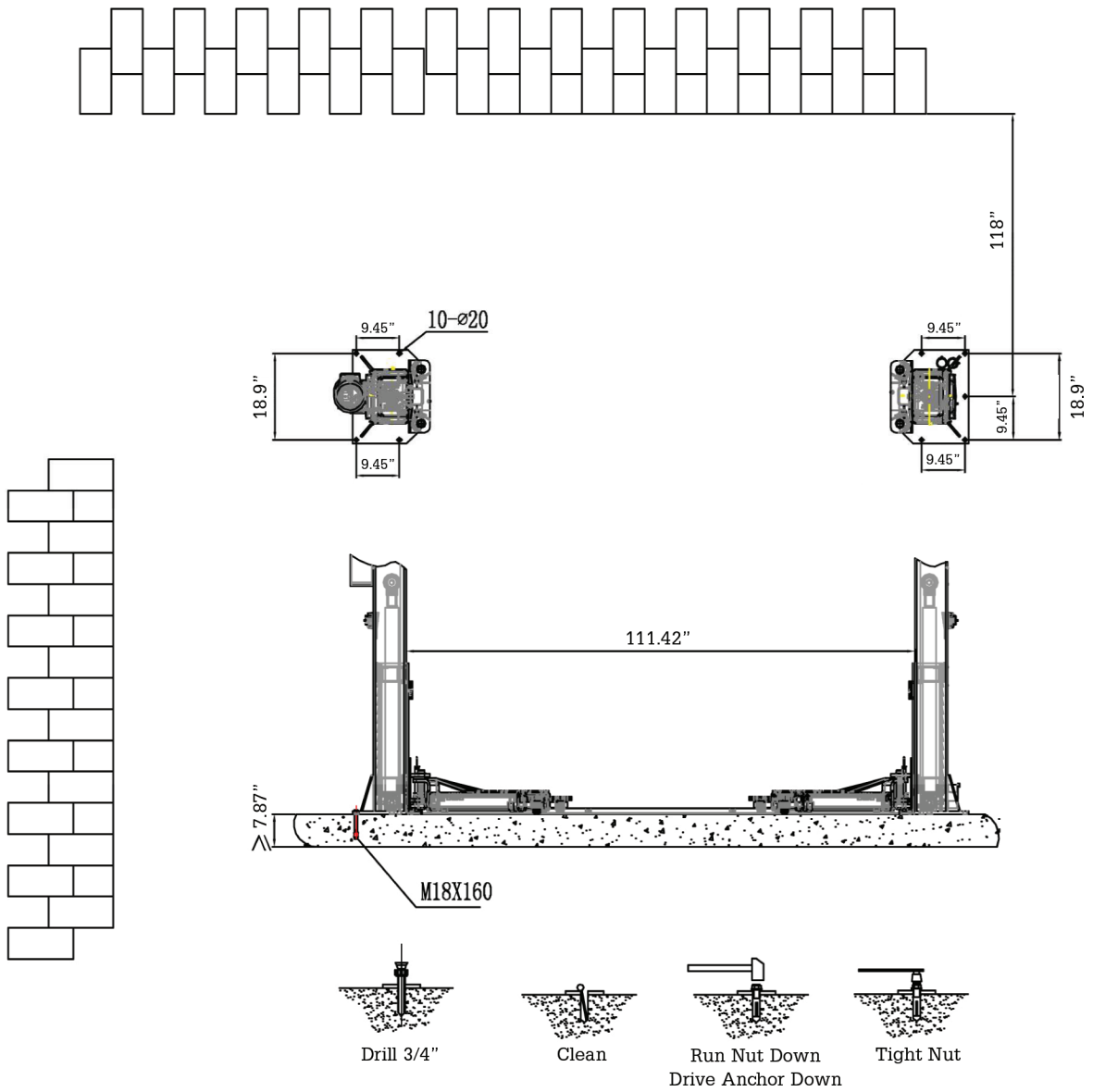
S/N	Material #	Name	Drawing #	Qty	Property	Note
29	202110005	Hex socket button head screw	GB/T70.2-2000	2	Standard	
30	204001004	Spring washer M8	GB/T93-1987	2	Standard	
31	410010081	Retaining ring	6254E-A5-B3	2	Zinc-plating	
32	410010031	Washer	6254E-A1-B3	2	Zinc-plating	
33	410010061	Up pulley	6254E-A5-B1	2	Zinc-plating	
34	205101008	Bearing 2518	SF-1	2	Standard	
35	614001003B	Top plate	6254E-A5-B2	2	Welded	

# FIG. 8 - 9000AFE

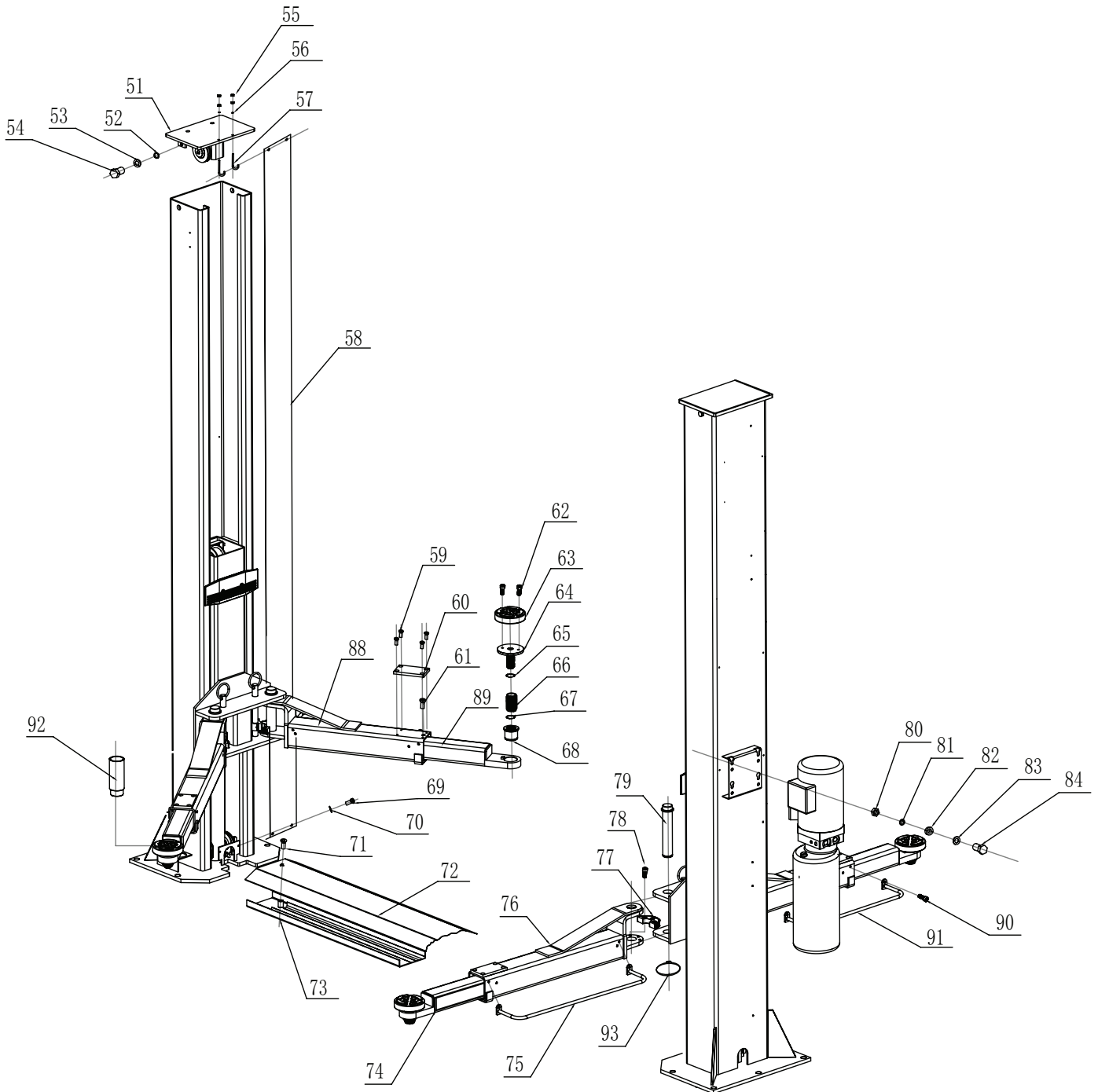


S/N	Material #	Name	Drawing #	Qty	Property	Note
21	410010131	Tension Spring	6254-A3-B2	2	65Mn	
22	615001012C	Safety lock	6254-A3-B4	2	Assembly	
23	410010141B	Bushing	6254-A3-B3	2	Q235A	
24	206201004	Cotter pin 3*45		2	Standard	
36	204301009	Circlip 25	GB/T894.2-1986	2	Standard	
37	410010031	Washer	6254E-A1-B3	2	Q235A	
38	205101007	Bearing 2512	SF-1	2	Standard	

# FIG. 9 - 9000AFE



# FIG. 10 - 9000AFE





S/N	Material #	Name	Drawing #	Qty	Property	Note
39	410040031	Down pulley	6254E-A1-B2	2	Q235A	
40	420010010	Slider	6254E-A2-B5	16	Nylon 1010	
41	612004006	Pulling rod	6254E-A2-B1	4	Welded	
42	410150121	Pressure spring	6254E-A2-B4	4	Zinc-plating	
43	410150111	Teeth block	6254E-A2-B3	4	Q235A	
44	206102006	Elastic cylindrical pin 5*35	GB/T879.1-2000	4	Standard	
45	204301008	Circlip 25	GB/T894.2-1986	2	Standard	
47	202103021	Cross sunken head screw M8*16	GB/T819.1-2000	4	Standard	
48	420010020	Door-opening protection pad	6254E-A2-B6	2	Rubber	
49	614008008	Carriage	6214D-A3-B1	2	Welded	
50	410010013B	Cover plate	6254-A1-B3	2	Q235A	

S/N	Material #	Name	Drawing #	Qty	Property	Note
51	615001004	Top plate	6254E-A5	2	Welded	
52	204101007	Flat washer M12	GB/T95-1985	4	Standard	
53	204201006	Spring washer M12	GB/T93-1987	4	Standard	
54	201102025	Hex head full swivel screw M12*20	GB/T5781-2000	4	Standard	
55	203101004	Hex nut M6	GB/T6170-2000	8	Standard	
56	204101004	Flat washer M6	GB/T95-1985	4	Standard	
57	410010051	Hook for chain protection cloth	6254E-A1-B5	4	Standard	
58	615001002	Chain protection cloth	6254E-A1-B4	2	Cloth	
59	202103008	Cross sunken head screw M5*10	GB/T819.1-2000	16	Standard	
60	420040040	Square pad	6254E-A7-B2	4	Rubber	
61	202103019	Cross sunken head bolt M8*10	GB/T819.1-2000	4	Standard	
62	202111007	Inside hex sunken head screw M8*20	GB/T70.2-2000	8	Standard	
63	420040050B	Round lifting pad	6254E-A7-B4-C4	4	Rubber	
64	612004002B	Lifting tray	6254E-A7-B4-C1	4	Welded	
65	204301008	Circlip 22	GB/T894.2-1986	4	Standard	
66	410040041	Swivel sheath	6254E-A7-B4-C2	4	Q235A	
67	204302004	Circlip 38*2.5	GB/T895.2-1986	8	Standard	
68	410040051	Inside swivel sheath	6254E-A7-B4-C3	4	Q245A	
69	202101027	Cross cap screw M6*8	GB/T818-2000	4	Standard	
70	204101004	Flat washer M6	GB/T95-1985	4	Standard	
71	202111014	Inside hex sunken head screw M12*20	GB/T70.2-2000	2	Standard	
72	410040013	Base cover plate	6254E-A10	1	Q235A	
73	614004017	Slot base plate	6254E-A9	1	Welded	
74	614004006	Long tensile arm	6254E-A7-B3	2	Welded	
75	614004014B	Fender for long arm	6254E-A7-B5	2	Welded	
76	614004005	Long arm	6254E-A7-B1	2	Welded	
77	410150131	Semi-teeth block	6254E-A7-B6	4	Q235A	
78	202109041	Inside hex cylinder head screw M10*20	GB/T70.1-2000	12	Standard	
79	612004004	Shaft	6254E-A12	4	Welded	
80	203101006	Hex nut M10	GB/T6170-2000	4	Standard	
81	204201005	Spring washer M10	GB/T93-1987	4	Standard	
82	420040010	Anti-shock pad	6254E-A23	4	Rubber	
83	204101006	Flat washer M10	GB/T95-1985	4	Standard	
84	201102020	Hex head full swivel screw M10*35	GB/T5781-2000	4	Standard	
88	614004008	Short arm	6254E-A08-B01	2	Welded	
89	614014010	Short tensile arm	6254E-A08-B02	2	Welded	
90	202110004	Inside hex button head screw M8*12	GB/T70.2-2000	8	Standard	
91	614004013B	Short arm fender	6254E-A8-B5	2	Welded	
92	612004003	Height adapter	6254E-A11	4	Welded	



# SPARE PARTS LIST

## Spare parts for the electrical system

S/N	Material#	Name	Spec.	Unit	Qty	Note
1	320901001	AC contactor	CJX2-1210/AC24	Pcs	1	
2	320301009	Limit switch	ME8104	Pcs	1	

## Spare parts for the mechanical part

S/N	Material#	Name	Spec.	Qty	Property	Note
1	420010010	Sliding block	6254E-A2-B5	16	Nylon 1010	
2	4200400508	Round rubber pad	6254E-A7-B4-C4	4	Rubber	
3	207101019	O-shape seal ring	(ID)23.6*3.55	1		
4	207102001	Y-shape seal ring	KD 63*48*10	1		
5	207105005	Anti-dust ring	DHS 40*48*5/6.5	1		

# NOTES

A series of 28 horizontal black lines spaced evenly down the page, providing a template for handwritten notes.



## LIMITED WARRANTY

The **Titan 2 Post lifts and 4 Post lifts** are backed by a standard **1 year** replacement parts warranty and a **5 year** structural warranty from the date of purchase, to the original purchaser only. The **1 year** replacement parts warranty covers power units, hydraulic cylinders, and all other assembly components such as, but not limited to: turn plates, slip plates, cables, chains, valves, switches etc. This does not cover normal wear items such as but not limited to rubber lifting pads and nylon slide blocks. Titan **HD2P-9000ACE-D** and **HD2P-9000AFE 2 Post lifts** are backed by a **2 year** replacement parts warranty and a **5 year** structural warranty from the date of purchase, to the original purchaser only. The **2 year** replacement parts warranty covers power units, hydraulic cylinders, and all other assembly components such as, but not limited to: turn plates, slip plates, cables, chains, valves, switches etc. This does not cover normal wear items such as but not limited to rubber lifting pads and nylon slide blocks.

**Titan Mid Rise Scissor lifts** are backed by a standard **1 year** replacement parts warranty and a **5 year** structural warranty from the date of purchase, to the original purchaser only. The **1 year** replacement parts warranty covers power units, hydraulic cylinders, and all other assembly components such as, but not limited to: turn plates, slip plates, cables, chains, valves, switches etc. This does not cover normal wear items such as but not limited to rubber lifting pads and nylon slide blocks.

**Titan Standard Duty and Heavy Duty motorcycle lifts** are backed by a standard **1 year** replacement parts warranty from the date of purchase, to the original purchaser only. The **1 year** replacement parts warranty covers power units, hydraulic cylinders, pneumatic cylinders, and all other assembly components such as, but not limited to: cables, caster wheels, valves, switches, wheel vises etc. This does not cover normal wear items such as but not limited to rubber wheel vise pads.

**Titan Bulldog Moto Cradle Wheel Chock** is warranted for replacement parts, only to the original purchaser, for a period of **2 years** from the date of purchase.

**Titan shop equipment products and accessories** are warranted for replacement parts only to the original purchaser for a period of **90 days** from the date of purchase. This **90 day** replacement parts warranty covers products such as but not limited to: EZ mover jacks, Mini Jacks, tie down products, shop and Bulldog Moto Cradle Wheel Chock accessories, dollies, stands, Light Duty Motorcycle Lifts, etc.

For **all** warranty considerations, Titan Marketing, LLC will supply replacement parts only during the warranty period. The original purchaser is responsible for all shipping, handling, and any labor charges incurred. All defective parts must be returned to Titan for inspection and examination. Any parts that are found to be defective will be replaced or repaired to proper working order. Other items not listed above may be considered general wear parts and therefore, will not be covered under warranty. These warranties **do not** extend to **defects** caused by ordinary wear, abuse, misuse, shipping damage, improper installation, voltage or lack of required maintenance. Titan Marketing, LLC is **not** to be held responsible for any **failure** that results from an accident, purchaser/operator abuse, neglect, or failure to operate products in accordance with instructions provided in the owner's manual(s) supplied. Damage caused by rain, excessive humidity, corrosive environments or other contaminants are not covered under warranty. **THESE WARRANTIES DO NOT EXTEND TO ANY COSMETIC DEFECT NOT INTERFERING WITH EQUIPMENT FUNCTIONALITY OR ANY INCIDENTAL, INDIRECT, OR CONSEQUENTIAL LOSS, DAMAGE, OR EXPENSE THAT MAY RESULT FROM ANY DEFECT, FAILURE OR MALFUNCTION OF A TITAN MARKETING LLC PRODUCT OR THE BREACH OR DELAY IN PERFORMANCE OF THE WARRANTY.**



## **WARNING**



The warnings, precautions and instructions in this manual cannot cover all possible conditions and situations that may occur. The operator must understand that the operator must supply common sense and examine caution factors when using this product to determine safety in all circumstances being used.



**TITAN MARKETING, LLC**

PO Box 7069 Greenwood, IN 46142  
1.888.908-4826 FAX (317) 215.2770  
[www.titanlifts.com](http://www.titanlifts.com)