



INSTALLATION, OPERATION, & MAINTENANCE MANUAL



MODELS:

**1000D-J / 1000D / 1000D-XLT
1,000 LB CAPACITY MOTORCYCLE/ATV LIFT**

*OPTIONAL EQUIPMENT SHOWN

⚠ FOLLOW THIS MANUAL CAREFULLY TO ENSURE THE MACHINE WILL FUNCTION CORRECTLY AND PROVIDE MANY YEARS OF DEPENDABLE SERVICE. FAILURE TO FOLLOW THESE INSTRUCTIONS AND SAFETY WARNINGS MAY RESULT IN PERSONAL INJURY OR PROPERTY DAMAGE. USE OF STRAPS IS RECOMMENDED - SOLD SEPARATELY. KEEP THIS MANUAL IN A SAFE DRY PLACE FOR FUTURE REFERENCE.



TITAN MARKETING, LLC

PO Box 7069 Greenwood, IN 46142
1.888.908-4826 FAX (317) 215.2770
www.titanlifts.com

To Our Valued Customers:

Thank you for purchasing a Titan Lifts® product. We hope this high quality equipment provides you with years of dependable service.

It is unfortunate that rare situations may occur with the products you purchase from Titan Lifts®. We value your business as well as the trust you have and need to maintain your relationship with us. Titan Lifts® carries liability coverage that may protect our customers if a situation does occur. However, as in all accidents there must be proof of liability for a claim to be made. Our insurance company requires the following procedures be observed in order to consider a claim:

- A. The claimant must contact the Titan Lifts® distributor immediately with the facts of the situation.
- B. If any equipment is damaged, including vehicles or shop equipment, Titan Lifts® must be given the opportunity to send an impartial representative to the site for proper assessment of the situation.
- C. The Vehicle cannot be moved until either an impartial representative has reviewed the accident or clear and precise pictures are taken that reflect all the pertinent information for an impartial representative to be able to access the information from a distance. Titan Lifts® or its representatives must approve the pictures before anything can be moved.
- D. If any potential liability is determined on behalf of Titan Lifts®, two estimates must be submitted for damages to be reimbursed.

It is imperative that the claimant complies with these procedures, because without proper assessment of the situation a claim will be denied.

ARBITRATION NOTICE

The installation or use of this equipment shall constitute an acknowledgement that the user agrees to resolve any and all disputes or claims of any kind whatsoever, which relate in any way to the equipment, by way of binding arbitration, not litigation. No suit or legal action may be filed in any state or federal court. Any arbitration shall be governed by the Federal Arbitration Act, and administered by the American Mediation Association, Indianapolis Indiana. The maximum amount that an arbitrator may award and all damages shall not exceed the retail value of this equipment.

WARRANTY NOTICE

This equipment must be installed by a "Professional Installer" assembled and used in the manner according to the documentation provided to be covered by warranty.

Damaged or missing components must be reported within 72 hours of receipt to your freight carrier and to the distributor. Claims must be filed to cover cost.

If you have any questions or if we can be of any further assistance, please don't hesitate to contact a Titan Lifts® representative at 1-888-908-4826. Thank you for the opportunity to continue to serve your lift equipment needs.

INSTRUCTIONS

 **WARNING:** READ ENTIRE MANUAL AND COMPLY WITH ALL SAFETY AND SERVICE PRECAUTIONS. DEATH, PERSONAL INJURY AND / OR PROPERTY DAMAGE MAY OCCUR IF INSTRUCTIONS ARE NOT FOLLOWED CAREFULLY.

UNPACKING AND SET-UP *REFER TO PARTS LIST FIG. 1

1. Carefully unpack the lift making sure that all of the parts have been included.
2. Remove the lift and all parts from delivery pallet and place on a clean, solid flat surface.
3. Safely, manually lift the Deck Plate (57) so that the Safety Bar (46) sits within the first safety latch. It is recommended at least two people perform this function.
4. **XLT ONLY:** Remove one of the Stabilization Pipe Caps (26) from the Stabilization Bar (27). Slide the stabilization bar through the square tubing of the Outside Lifting Arm (28) and place the stabilization cap back on the end. Secure the Stabilization Bar in place with the steel Ball Pins (25).
5. If using the Front Extension (55), slide the front extension over the front of the deck plate so that the support pipe holes align. Hold the front extension in place by connecting the Eye Bolts (56) with a Washer $\Phi 10$ (23) and Nut M10 (24) (Optional Equipment).
6. Take the Fixed Clamp (63) and bolt it to the Deck Plate (57) or Front Extension (55) using the provided bolts (64), Washers $\Phi 10$ (23) and Nuts M10 (24). Insert the Tire Stop (61) onto the Fixed Clamp using the Pin (62) (Optional Equipment).
7. Take the Crank Assembly (60) and bolt it to the Deck Plate (57) or Front Extension (55) using the Provided Bolts (64.1), Washers $\Phi 10$ (23) and Nuts M10 (24). Bolt Moveable Clamp (84) to Crank Assembly (60) using the provided Bolts (81) (Optional Equipment).
8. If using the Side Extensions (52), slide the Support Pipes (53) through Support Pipe holes in the front and rear of the Deck Plate (57). Slide the Side Extensions over the Support Pipes and secure in place with the Quick Pins (54).
9. Hook the Ramp (58) and Extension Panels (51) onto the back of the Deck Plate (57) and Side Extensions (52).
10. Take ends of Air Hose (2) and attach to Foot Operated Air Valve (1) and the Front Cover (6) of the cylinder.
11. Attach compressed air to the Foot Operated Air Valve (1) to 100 PSI air supply and raise the lift by moving the valve to the up position. Requires 90-100PSI air supply.

 **WARNING:** The lift may be damaged and/or personal injury may result if the pressure exceeds the maximum 100 PSI rating.

 **Note:** Use caution that mounting bolts for Fixed Clamp (63) do not interfere with the frame support bar movement when using the front extension.

 **Note:** Standard Dropout Plate (59) can be removed for easy rear wheel removal. Roller Dropout Plate (78) can be installed after motorcycle is loaded for easy rear wheel cleaning or maintenance.

 **WARNING:** Roller Dropout Plate (78) must be removed prior to unloading the motorcycle from the lift & replaced with the Standard Dropout (59). Do NOT operate motorcycle on Roller Dropout (78). Roller Dropout (78) is not to be used as a dyno device.

OPERATION & MAINTENANCE

***REFER TO PARTS LIST FIG. 1**

*** Test the lift several times for proper operation before attempting to lift a load.**

1. All moving parts have been lubricated at the factory and should be re-lubricated before the first use and at least once every six months to prevent damage. Grease fittings are located at each frame pivot shaft and at the top ends of the inside frame assembly.
2. Lightly oil cylinder rod at least once every six months or when it becomes dry.
3. Squirt some oil through the bleed hole in the plate at the end of the cylinder to lubricate piston and seal every six months.
4. The pivot shaft set screws should be checked frequently to be sure they are tight. These are located at the top end of the inside frame assembly.
5. Do NOT use this product if worn or damaged. Examine lift for structural cracks, bends, or other signs of damage prior to each use. Check all hoses and connections before each use to ensure proper working condition.
6. Keep lift clean, dry, and well maintained to extend longevity of the product.
7. Roll motorcycle onto Deck Plate (57) until wheel is inside the Clamp (84 & 63).
8. Tighten the clamp to the tire by using the crank handle on the Moveable Clamp (60).
9. Load must be centered on the table at all times.
10. Load must be firmly positioned and secured on the table at all times.
11. To raise the lift, make sure that the compressed air is connected and use the Foot Operated Air Valve (1) until you reach the desired working height.
12. **IMPORTANT:** After reaching the desired working height, lower the lift so that the Safety Bar (46) sits firmly in the safety latch and all pressure is off of the Cylinder (20). Remove air supply from Foot Operated Air Valve (1).
13. When finished working, attach air supply to Foot Operated Air Valve (1), raise the lift to release the Safety Bar (46) and place it back into Deck Plate (57). Slowly release the air from the Cylinder (20) until the lift rests gently on the ground.

 **WARNING:** Do NOT load the motorcycle onto Deck Plate (57) with the Roller Dropout (78) installed. Use the Standard Dropout Plate (59) when loading motorcycle.

 **WARNING:** The Safety Bar (46) should be down securely in the safety lock when the lift is in the raised position so that the lift does not lower.

WARNING

The warnings, precautions and instructions in this manual cannot cover all possible conditions and situations that may occur. The operator must understand that the operator must supply common sense and examine caution factors when using this product to determine safety in all circumstances being used.

SAFETY PRECAUTIONS

1. Load should not exceed rated capacity for this lift - 1000lbs
2. 90-100PSI shop air needed. Do NOT exceed the 100 PSI rating.
3. Make sure the safety bar is down in the locked position while the lift is in the raised position.
4. Move the lift only when it is lowered.
5. Do NOT ride vehicle onto lift.
6. Only trained people should operate the lift.
7. Foot operated air valve should be at least 3 feet away when operating. Remain clear of the lift when raising or lowering.
8. Indoor use recommended.
9. Do NOT move lift while loaded.
10. Keep hands, tools and other extremities from under carriage and moving parts.
11. Maintain a safe working environment. The work area should be clean, dry, clutter free and sufficiently lit.
12. Wear proper ANSI-approved safety attire. Do NOT wear loose fitting clothing while operating lift. Long hair and sleeves should be secured.
13. Keep children and bystanders away from work area. Do NOT let children operate or play on lift.
14. Do NOT use if under the influence of drugs or alcohol. Operator must be alert at all times when using heavy lift equipment.
15. Never operate the lift with someone on it.
16. Use this lift only for the work it is intended. Do NOT use this product for an application for which it was not designed. Misuse can lead to personal injury and/or property damage.
17. Industrial applications must follow OSHA requirements.
18. Do NOT use for aircraft purposes.
19. Have your lift serviced by a qualified repair person using only identical Titan Lifts® replacement parts and attachments. This will ensure that the safety of the lift is maintained.

PLEASE READ THE FOLLOWING CAREFULLY

THE MANUFACTURER AND/OR DISTRIBUTOR HAS PROVIDED THE PARTS LIST AND ASSEMBLY DIAGRAM IN THIS MANUAL AS A REFERENCE TOOL ONLY. THE MANUFACTURER OR DISTRIBUTOR DOES NOT MAKE ANY REPRESENTATION OR WARRANTY OF ANY KIND TO THE BUYER THAT HE OR SHE IS QUALIFIED TO MAKE ANY REPAIRS TO THE PRODUCT, OR THAT HE OR SHE IS QUALIFIED TO REPLACE ANY PARTS OF THE PRODUCT. THE MANUFACTURER AND/OR DISTRIBUTOR EXPRESSLY STATES THAT ALL REPAIRS AND PARTS REPLACEMENTS SHOULD BE PERFORMED BY CERTIFIED AND LICENSED TECHNICIANS, AND NOT BY THE BUYER. THE BUYER ASSUMES ALL RISK AND LIABILITY ARISING OUT OF HIS OR HER REPAIRS TO THE ORIGINAL PRODUCT OR REPLACEMENT PARTS THERETO, OR ARISING OUT OF HIS OR HER INSTALLATION OF REPLACEMENT PARTS THERETO.

Product's Serial Number: _____

Note: If product does not have a serial number, record the month and year of purchase instead.

Note: Some parts are listed and shown for illustration purposes only, and are not available individually as replacement parts.

FRONT WHEEL CLAMP INSTALLATION DRAWING

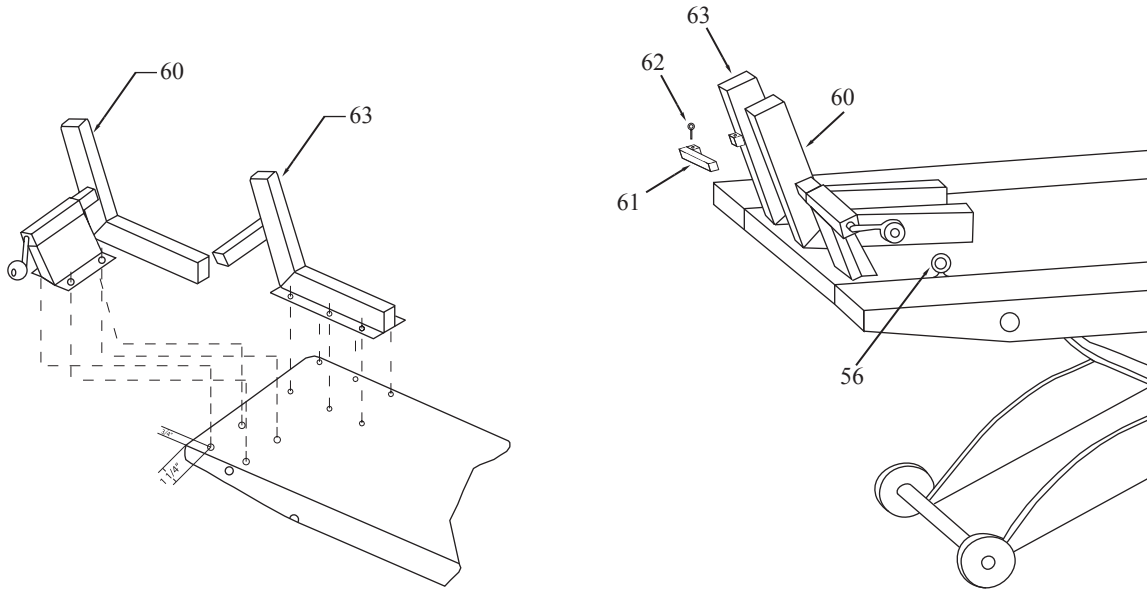

FRONT EXTENSION INSTALLATION DRAWING

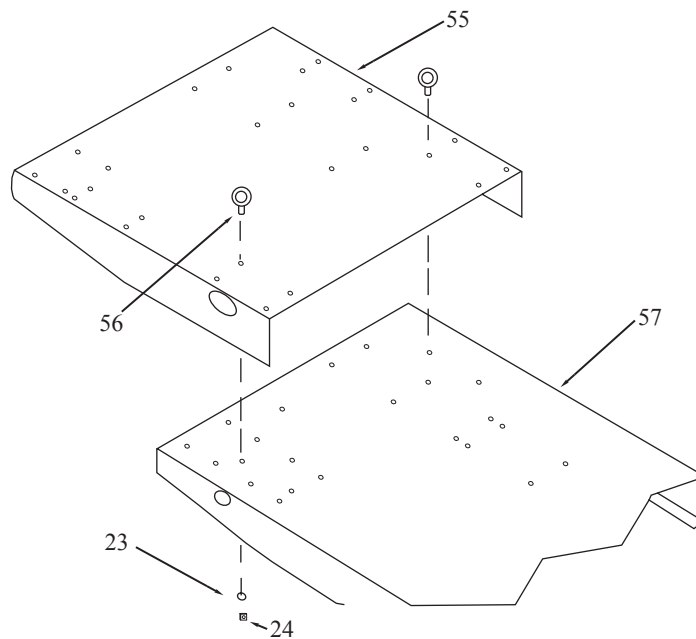

SIDE EXTENSIONS INSTALLATION DRAWING (XLT ONLY)

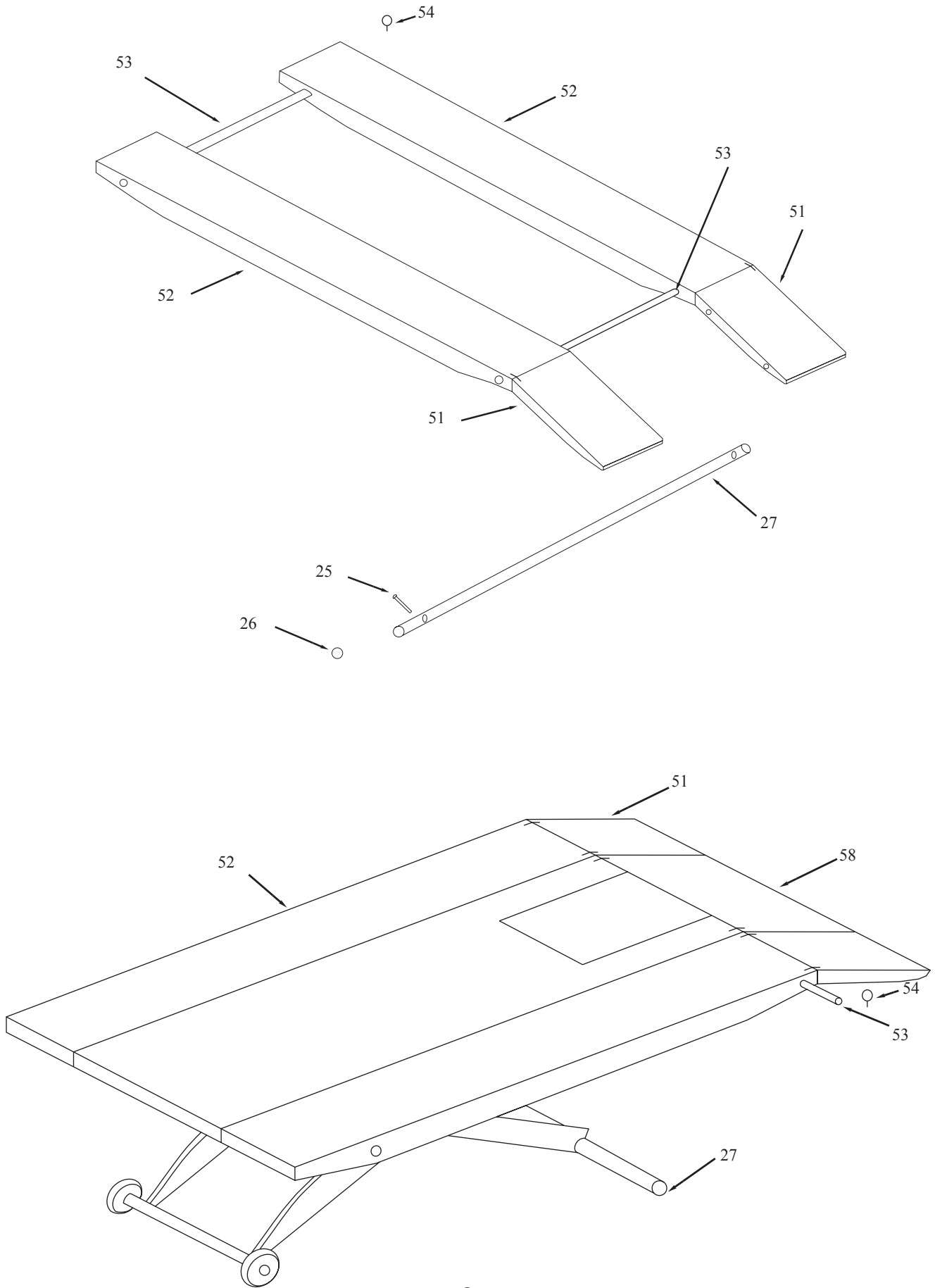

PARTS LIST (FIG. 1)

PLEASE MAKE SURE TO CONFIRM THAT ALL PARTS ARE INCLUDED.

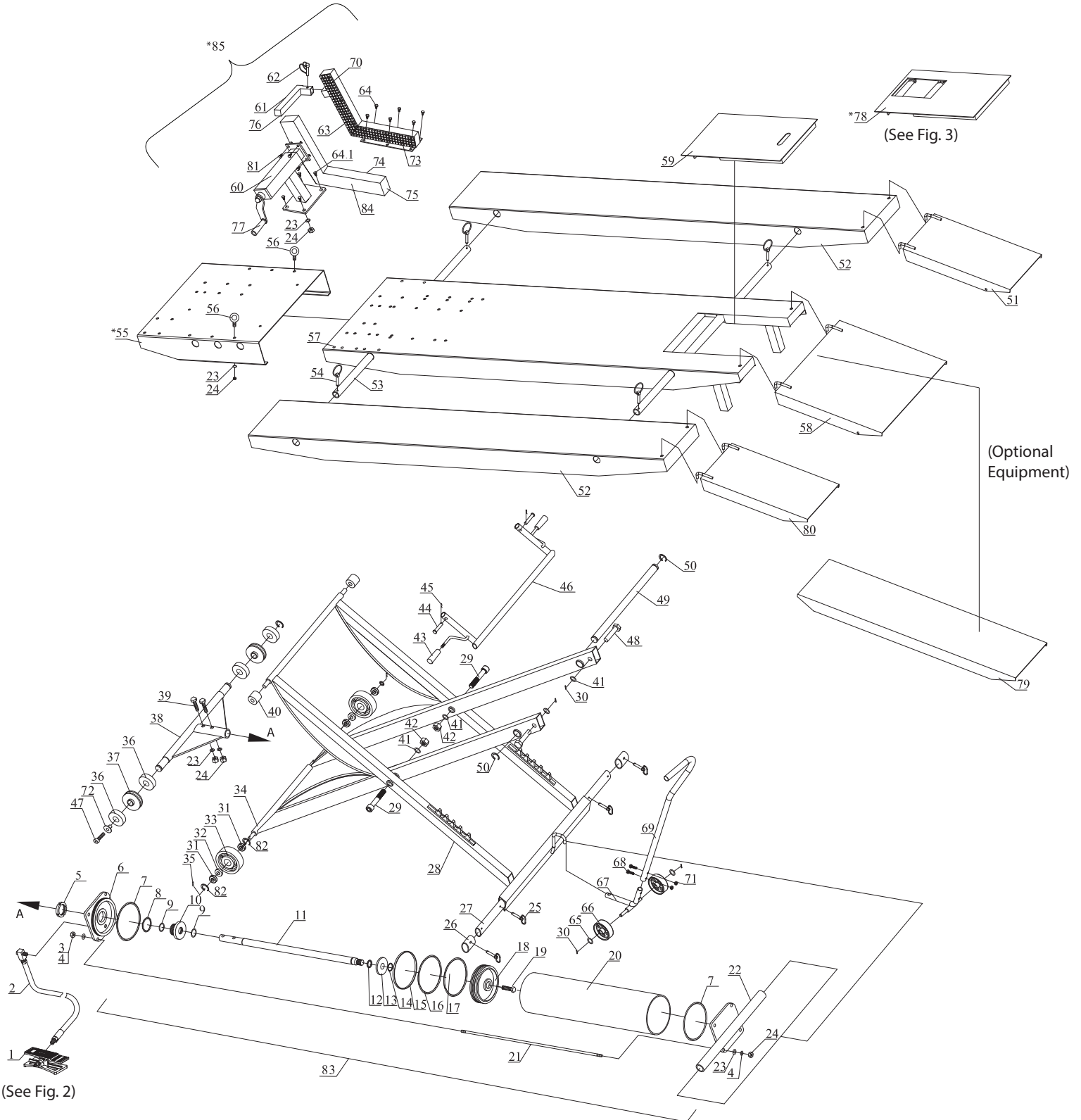

PARTS LIST CON'T. (FIG. 1)

NO.	DESCRIPTION	QTY	NO	DESCRIPTION	QTY
1	FOOT OPERATED AIR VALVE - Fig. 2	1	44	PIN	2
2	AIR HOSE	1	45	R-PIN	2
3	SCREW CAP M10	4	46	SAFETY BAR (COLOR)	1
4	WASHER Φ 10	8	47	MACHINE BOLT	2
5	NUT	1	48	PIN	2
6	FRONT COVER	1	49	CYLINDER PIVOT SHAFT	1
7	NYLON O-RING	2	50	RETAINING RING	2
8	O-RING	1	51	RIGHT EXTENSION RAMP - XLT ONLY	2
9	O-RING	2	52	SIDE EXTENSION - XLT ONLY	2
10	SHAFT BUSHING	1	53	SUPPORT PIPE - XLT ONLY	2
11	PISTON ROD	1	54	QUICK PIN - XLT ONLY	4
12	RETAINING RING	1	55	*FRONT EXTENSION	1
13	PRESS RING	1	56	EYE BOLT	2
14	O-RING	1	57	DECK PLATE	1
15	PLASTIC O-RING	1	58	MAIN RAMP	1
16	O-RING	1	59	STANDARD DROPOUT PLATE (COLOR)	1
17	O-RING	1	60	CRANK ASSEMBLY (COLOR)	1
18	PISTON	1	61	TIRE STOP (COLOR)	1
19	BOLT	1	62	WHEEL STOP PIN	1
20	CYLINDER CASING	1	63	FIXED CLAMP (COLOR)	1
21	STAY BOLT	4	64	BOLT 18mm	6
22	CYLINDER END PLATE	1	64.1	BOLT 25mm	4
23	WASHER Φ 10	12	65	WASHER PRESS RING	2
24	NUT M10	12	66	DOLLY WHEEL	2
25	STEEL BALL PIN - XLT ONLY	4	67	DOLLY BASE (COLOR)	1
26	STABILIZATION PIPE CAP - XLT ONLY	2	68	BOLT	2
27	STABILIZATION BAR - XLT ONLY	1	69	DOLLY HANDLE (COLOR)	1
28	LIFTING ARM - OUTSIDE (COLOR)	1	70	FLAT HEAD MACHINE SCREW	24
29	INNER HEXAGON SCREW	2	71	NUT	2
30	COTTER	4	72	PRESS RING	2
31	BEARING	4	73	RUBBER VISE PAD - RIGHT	1
32	PRESS RING	2	74	RUBBER VISE PAD - LEFT	1
33	WHEEL (COLOR)	2	75	PLASTIC VISE END CAP - BLK	4
34	LIFTING ARM - INSIDE (COLOR)	1	76	PLASTIC WHEEL STOP END CAP - BLK	2
35	RETAINGING RING	2	77	VISE HANDLE - PLASTIC	1
36	BEARING	4	78	*ROLLER DROPOUT - Fig. 3 (COLOR)	1
37	PRESS RING	2	79	LONG RAMP	1
38	CONNECTION (COLOR)	1	80	LEFT EXTENSION RAMP - XLT ONLY	1
39	BOLT M10*45	2	81	BOLT (VISE ATTACHMENT)	4
40	ROLLER	2	82	RETAINING RING	4
41	WASHER Φ 16	4	83	COMPLETE CYLINDER ASSEMBLY	1
42	LOCK NUT M16	2	84	MOVEABLE CLAMP (COLOR)	1
43	SAFETY BAR HANDLE	2	85	*COMPLETE VISE ASSEMBLY (COLOR)	1

*OPTIONAL EQUIPMENT

FOOT VALVE PARTS DETAIL (FIG. 2)

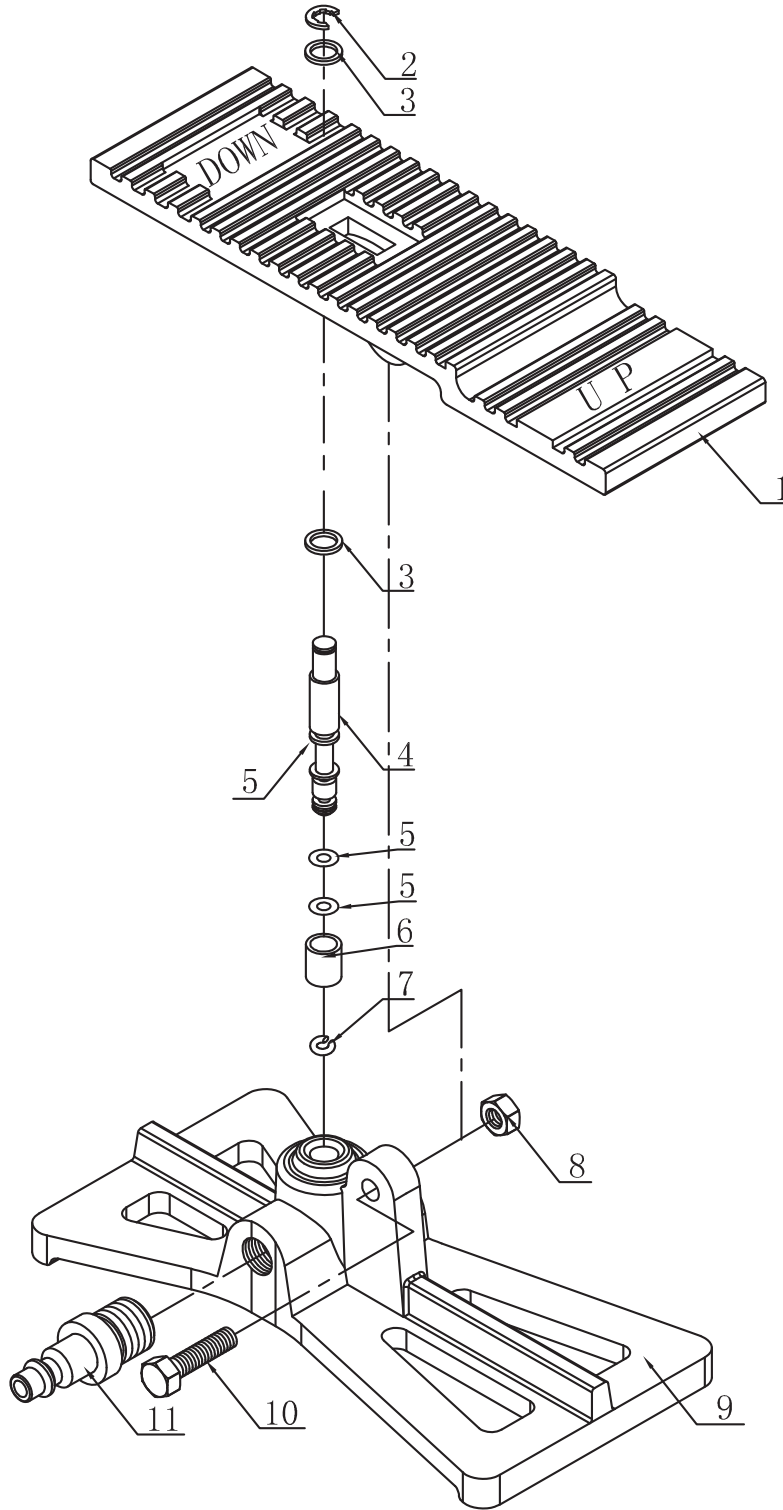

NO.	DESCRIPTION	QTY	NO	DESCRIPTION	QTY
1	FOOT PEDAL	1	7	SNAP RING	1
2	RETAINING RING	1	8	LOCK NUT	1
3	WASHER	2	9	BASE	1
4	PLUNGER VALVE	1	10	HEXAGON BOLT	1
5	O-RING	3	11	AIR FITTING	1
6	NYLON BUSHING	1			

ROLLER DROP-OUT PARTS DETAIL (FIG. 3)

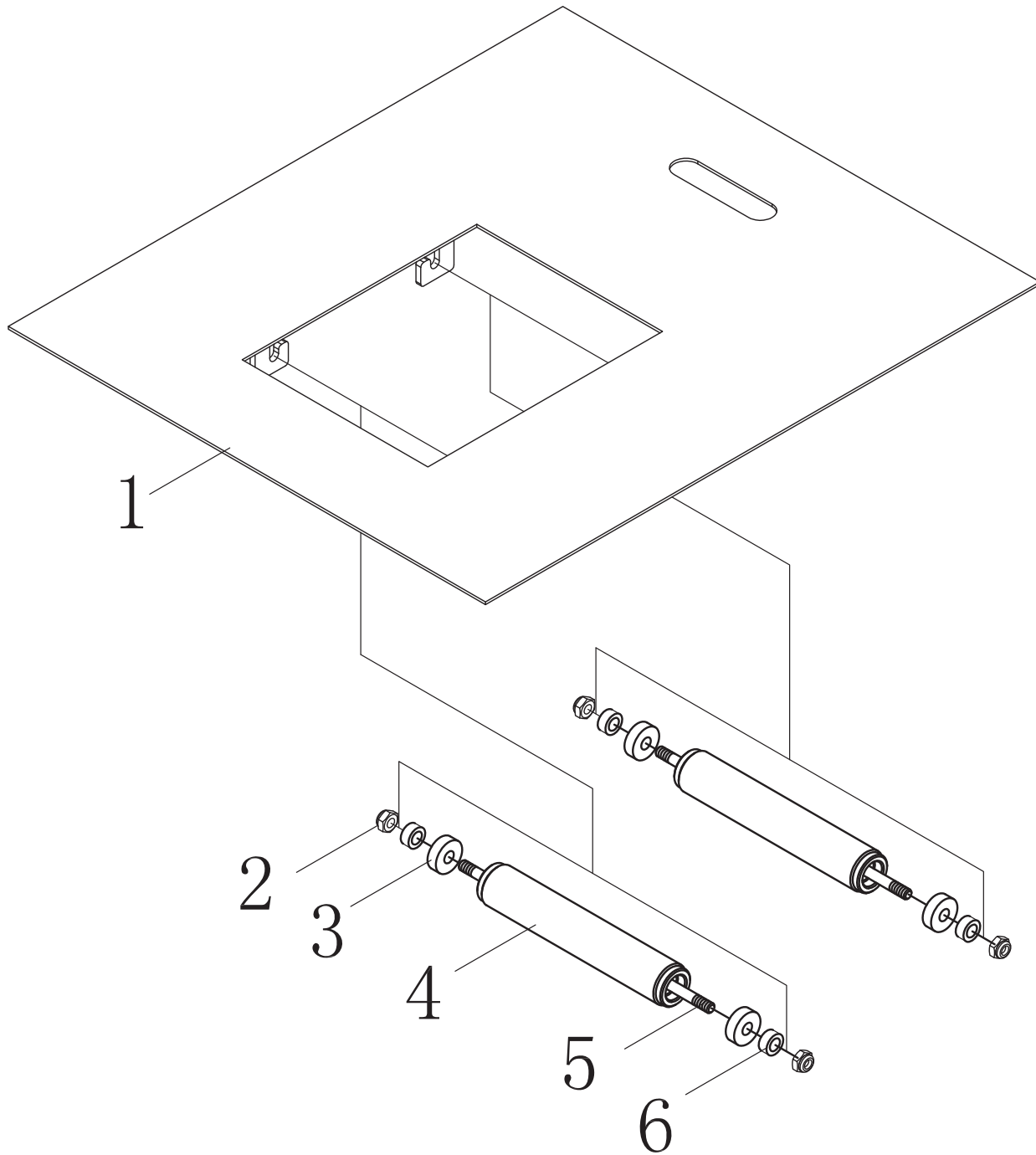

NO.	DESCRIPTION	QTY
1	DROPOUT PLATE (COLOR)	1
2	RETAINING NUT M8	4
3	BEARING	4
4	ROLLER	2
5	PIN	2
6	BUSHING	4



WARNING



The warnings, precautions and instructions in this manual cannot cover all possible conditions and situations that may occur. The operator must understand that the operator must supply common sense and examine caution factors when using this product to determine safety in all circumstances being used.



TITAN MARKETING, LLC

PO Box 7069 Greenwood, IN 46142
1.888.908-4826 FAX (317) 215.2770
www.titanlifts.com

**Patent No.: US 8,104,588 B2
CA 2,729,670**

Revision 8