



INSTALLATION, OPERATION, & MAINTENANCE MANUAL



MODEL:

TC-350

37" Economy Tire Changer

⚠ FOLLOW THIS MANUAL CAREFULLY TO ENSURE THE MACHINE WILL FUNCTION CORRECTLY AND PROVIDE MANY YEARS OF DEPENDABLE SERVICE. FAILURE TO FOLLOW THESE INSTRUCTIONS AND SAFETY WARNINGS MAY RESULT IN PERSONAL INJURY OR PROPERTY DAMAGE. KEEP THIS MANUAL IN A SAFE DRY PLACE FOR FUTURE REFERENCE.



TITAN MARKETING, LLC

PO Box 7069 Greenwood, IN 46142
1.888.908-4826 FAX (317) 215.2770
www.titanlifts.com

To Our Valued Customers:

Thank you for purchasing a Titan Lifts® product. We hope this high quality equipment provides you with years of dependable service.

It is unfortunate that rare situations may occur with the products you purchase from Titan Lifts®. We value your business as well as the trust you have and need to maintain your relationship with us. Titan Lifts® carries liability coverage that may protect our customers if a situation does occur. However, as in all accidents there must be proof of liability for a claim to be made. Our insurance company requires the following procedures be observed in order to consider a claim:

- A. The claimant must contact the Titan Lifts® distributor immediately with the facts of the situation.
- B. If any equipment is damaged, including vehicles or shop equipment, Titan Lifts® must be given the opportunity to send an impartial representative to the site for proper assessment of the situation.
- C. The Vehicle cannot be moved until either an impartial representative has reviewed the accident or clear and precise pictures are taken that reflect all the pertinent information for an impartial representative to be able to access the information from a distance. Titan Lifts® or its representatives must approve the pictures before anything can be moved.
- D. If any potential liability is determined on behalf of Titan Lifts®, two estimates must be submitted for damages to be reimbursed.

It is imperative that the claimant complies with these procedures, because without proper assessment of the situation a claim will be denied.

ARBITRATION NOTICE

The installation or use of this equipment shall constitute an acknowledgement that the user agrees to resolve any and all disputes or claims of any kind whatsoever, which relate in any way to the equipment, by way of binding arbitration, not litigation. No suit or legal action may be filed in any state or federal court. Any arbitration shall be governed by the Federal Arbitration Act, and administered by the American Mediation Association, Indianapolis Indiana. The maximum amount that an arbitrator may award and all damages shall not exceed the retail value of this equipment.

WARRANTY NOTICE

This equipment must be installed by a "Professional Installer" assembled and used in the manner according to the documentation provided to be covered by warranty.

Damaged or missing components must be reported within 72 hours of receipt to your freight carrier and to the distributor. Claims must be filed to cover cost.

If you have any questions or if we can be of any further assistance, please don't hesitate to contact a Titan Lifts® representative at 1-888-908-4826. Thank you for the opportunity to continue to serve your lift equipment needs.

CONTENTS

1. Safety	Page 1
1.1 Introduction	Page 1
1.2 Safety Instructions for Operation.....	Page 1
1.3 Safety Instructions for Maintenance.....	Page 2
1.4 Warning Label Explanation	Page 3
1.5 Description	Page 3
2. Unpacking and set-up	Page 4
2.1 Delivery & check of packages	Page 5
2.2 Lifting & handling.....	Page 5
3. Specifications	Page 5
4. Installation Instructions	Page 6
5. Operation Instructions.....	Page 9
5.1 Dismounting a tire	Page 9
5.2 Mounting a tire	Page 10
5.3 Inflating a tire.....	Page 11
6. Maintenance.....	Page 11
6.1 Maintenance schedule	Page 11
6.2 Hexangular shaft & lock plate gap adjustment.....	Page 12
7. Troubleshooting	Page 15
8. Limited Warranty	Page 17

INSTRUCTIONS

1.SAFETY

1.1 INTRODUCTION



WARNING: READ ENTIRE MANUAL AND COMPLY WITH ALL SAFETY AND SERVICE PRECAUTIONS. DEATH, PERSONAL INJURY AND / OR PROPERTY DAMAGE MAY OCCUR IF INSTRUCTIONS ARE NOT FOLLOWED CAREFULLY.

Personal injury and property damage incurred due to non-compliance with these safety instructions are not covered by the product liability regulations.

SYMBOLS



FAILURE TO COMPLY WITH INSTRUCTIONS COULD RESULT IN PERSONAL INJURY.



FAILURE TO COMPLY WITH INSTRUCTIONS COULD RESULT IN PROPERTY DAMAGE.



IMPORTANT INFORMATION.

1.2 SAFETY INSTRUCTIONS FOR OPERATION

- Read this entire manual.
- Only trained authorized personnel over the age of 18 years should operate the machine.
- Strictly indoor use recommended.
- Maintain a safe working environment. The work area should be clean, dry, clutter free, and sufficiently lit.
- Do not operate the machine in explosive atmospheres, such as in the presence of flammable liquids, gases, or dust. Power equipment can create sparks which may ignite flammables.
- Keep hands, tools, and other extremities away from moving parts and pinching hazards.
- Never operate this machine with someone on it.
- Keep children and bystanders away from work area. Do not let children operate or play on machine.
- Wear proper safety attire. Do not wear loose fitting clothing while operating machine. Long hair, jewelry and sleeves should be secured.

- Never leave the machine unattended while in operation.
- Do not operate this machine under the influence of drugs, alcohol, or medication. Operator must be alert at all times when using this machine.
- Comply with all applicable accident prevention regulations.
- Use this machine only for the work it is intended. Do not use this product for an application for which it was not designed. Misuse can lead to personal injury and/or property damage.
- Do not reach any part of your body under the demount head.
- When clamping the wheel, do not reach any part of your body between the clamp and wheel.
- When breaking tire bead, the bead breaker will move quickly toward the machine. Keep body parts away from bead breaker during the process.
- During inflation, ensure that the wheel is clamped firmly.



WARNING: Use this machine only in well ventilated areas. Carbon monoxide exhausted from running vehicle engines is a colorless, odorless fume that, if inhaled, can cause serious personal injury or death.



WARNING: People with pacemakers should consult their physician(s) before using this product. Operation of electrical equipment in close proximity to a heart pacemaker could cause interference or failure of the pacemaker.



WARNING: This product contains or produces a chemical known to the State of California to cause cancer and birth defects (or other reproductive harm). (California Health & Safety Code 25249.5 et seq.)

1.3 SAFETY INSTRUCTIONS FOR MAINTENANCE

- Maintenance or repair work should be done by authorized service personnel only.
- Work on the electrical equipment should be done by certified licensed electricians only.
- Ensure that ecologically harmful substances are disposed of in accordance with the appropriate regulations.
- To prevent the risk of damage, do not use high pressure / steam jet cleaners or caustic cleaning agents.
- Do not replace or override the safety devices.

1.4 WARNING LABEL EXPLANATION



Electrical shock!



Do not reach any part of your body under the dismounting tool.



When breaking bead, the bead breaker blade will move quickly toward the machine.



Note: When pressing the tire, the opened clamp cylinder may injure the hand of the operator. Remember not to touch the side wall of the tire.



When clamping the rim, do not reach any part of your body between the clamp and the rim.



Do not stand behind the column to avoid the column from injuring you while swinging.



During inflation, ensure the wheel is clamped firmly.

While operating, do not wear long hair, loose clothing or jewelry.

While operating, keep yourself clear of potential falling objects.

1.5 DESCRIPTION

The model numbers covered in this manual are designated below:

TC-350: 37" economy tire changer.

This is a fixed-column economy tire changer with a rocker arm. It is used to mount, dismount, and inflate all types of tires of compatible size.

Proper application of the equipment described herein is limited to the parameters detailed in the specifications and the uses set forth in the descriptive passages. Any other proposed application of this equipment should be documented and submitted in writing to the factory for examination. The user assumes full responsibility for any equipment damage, personal injury, or alteration of the equipment described in this manual or any subsequent damages.

2. UNPACKING, & SET-UP

CONFIGURATION AND OPERATION

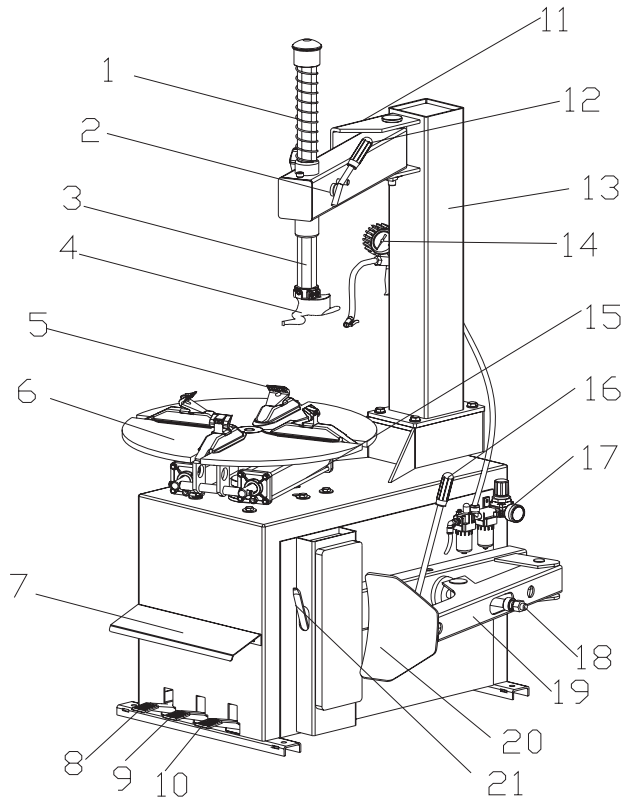

FIG 2

INSTALLATION AND CALIBRATION

- | | |
|-------------------------|----------------------------|
| 1-vertical shaft spring | 2 – rocker valve |
| 3- hexagon shaft | 4- dismount head |
| 5- claw | 6- turntable |
| 7-operation label | 8- turntable pedal |
| 9- clamp pedal | 10- tire press pedal |
| 11- limit handle | 12- lock handle |
| 13- column | 14- inflation gun |
| 15- clamp cylinder | 16- blade handle |
| 17- air source fitting | 18- bead breaking cylinder |
| 19- tire press arm | 20 -bead breaking blade |
| 21- crowbar | 22- air tank |
| 23- inflation gauge box | |

Before installation and calibration, carefully read this manual. The unauthorized modification of the parts and spare parts of the machine may cause damage to the machine.

Installation and calibration personnel should have the required electrical knowledge.

Operators must be trained and authorized.

Before installation, carefully read the equipment list. If there are any discrepancies or questions, please contact Titan Lifts.

Tools required for installation:

- Wrenches
- Sockets and wrench
- Hex wrench
- Tung
- Screw driver
- Hammer
- Multi-purpose meter

2.1 DELIVERY AND CHECK OF PACKAGES

When the machine is delivered, carefully unpack the machine making sure all the parts have been included. Check for possible damages due to transport and storage; verify that what is specified in the confirmation of order is included. In case of damage in transit, the customer must immediately inform the carrier of the problem.

Remove the machine and all parts from delivery pallet and place on a clean, solid, flat surface. Packages must be opened paying attention not to cause damage to people (keep a safe distance when opening straps) and parts of the machine (be careful the objects do not drop from the package when opening.)

***Titan Lifts must be notified within 72 hours if any components are damaged or missing.**

2.2 LIFTING AND HANDLING

When loading/unloading or transporting the equipment to the site, be sure to use suitable loading (e.g. cranes, trucks) and hoisting means. Be sure to hoist and transport the components securely so that they cannot drop, taking into consideration the package's size, weight, center of gravity, and its fragile parts.



LIFT AND HANDLE ONLY ONE PACKAGE AT A TIME

3. SPECIFICATIONS

Model	Height	Length	Width	Shipping Weight
TC-350	71.5"	38"	31.5"	475 lb

Model	Operating Pressure	Motor	Turntable Speed	Noise
TC-350	8-10 bar	110V	6 rpm	<70dB

Model	Max Tire Diameter	Max Wheel Width	Wheel Diameter (outer clamp)	Wheel Diameter (inner clamp)
TC-350	37"	12"	10" - 18"	12" - 21"

ENVIRONMENT REQUIREMENTS

Model	Ambient Temperature	Relative Humidity	Sea Level
TC-350	32°F - 113°F	30 - 95%	Max 3280'

4. INSTALLATION INSTRUCTIONS

PLEASE READ THIS INSTRUCTION BEFORE STARTING TO OPERATE THE MACHINE.

STEP 1: After removing the packaging crate, take out the accessory boxes (Fig 4-1), bead breaking arm (Fig 4-5) and column assembly (Fig4-2). Remove the bolt (Fig 4-4), elastic washer and plate washer on the body.

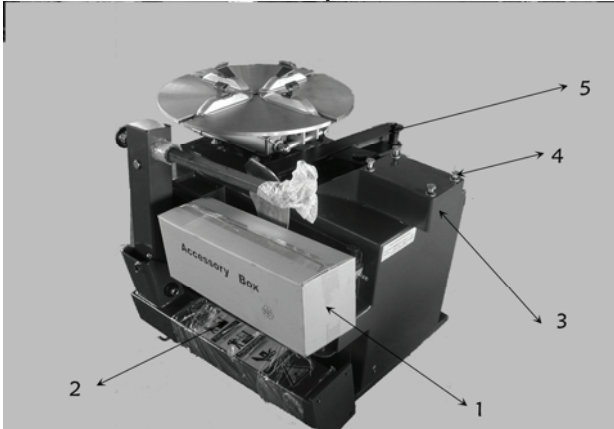

FIG 4

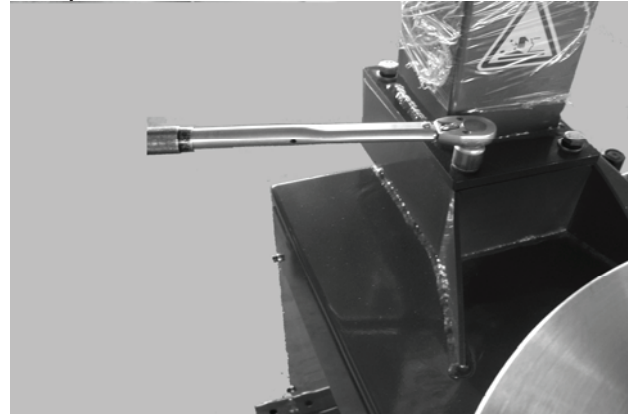

FIG 5

STEP 2: Place the column on the body with the warning labels facing the front of the machine. Make the holes on the column base plate align with the thread holes on the body. Install the bolt, elastic washer and plate washer that was removed in step 1 (Fig 5).

STEP 3: Use the wrench to remove the screw (Fig 6-3) hexangular shaft (Fig 6-1) and take off the vertical shaft cap (Fig 6-2). When removing the screw on the vertical shaft cap, you need to use the lock handle to lock the hexangular shaft to avoid sliding off and damaging the machine or personnel.



FIG 6

STEP 4: Install the vertical shaft spring (Fig 7-1) on the vertical shaft. Mount the vertical shaft cap and mount the removed screw and assemble the hand wheel into the nut bushing of the rocker arm (Fig7-2).

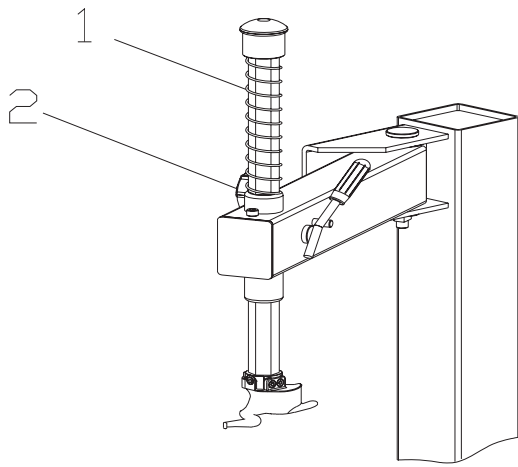

FIG 7

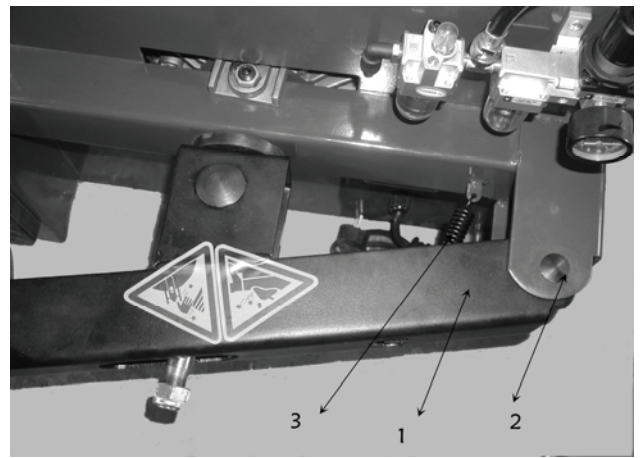

FIG 9

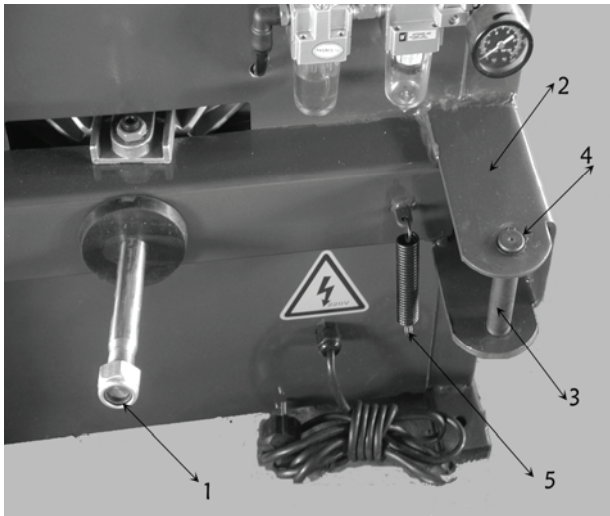

FIG 8

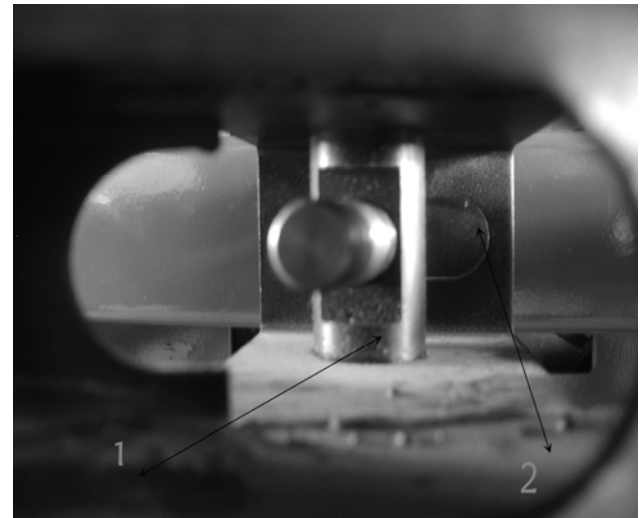

FIG 10

- STEP 5: Remove the lock nut at the front end of the bead breaking cylinder piston rod (Fig 8-1) and use the wench to remove the nut on the bead breaking arm bolt (Fig 8-4). Remove the bolt (Fig 8-3) and hang the spring (Fig 8-2).
- STEP 6: Position the bead breaking arm shaft bushing into the bead breaking support plate on the body (Fig 9-1) to align the hole and install the bead breaking bolt (Fig 9-2) and assemble the nut to lock (Fig 8-4). Insert the piston rod (Fig 10-2) through the hole of the bead breaking slide bushing (Fig 10-1). The surface of the slide bushing should be facing outwards (Fig 10). Assemble the removed nut (Fig 8-1) into the front end of the piston rod. The nut will be assembled. The distance from the edge of the bead breaking blade to the bead breaking rubber is 1.2" - 1.5" (Fig 11). Hang the spring (Fig 9-3). Open the side panel and insert the 2 pieces of Ø12 hose at the inlet of the quick deflation valve into the 2 Ø12 nozzle and then replace the side panel.
- STEP 7: **AIR SOURCE FITTING INSTALLATION:** Remove the air source fitting and screw from the accessory box and remove all oil and dust. Use the screw to fix it on the right side of the body (Fig 12).



FIG 11

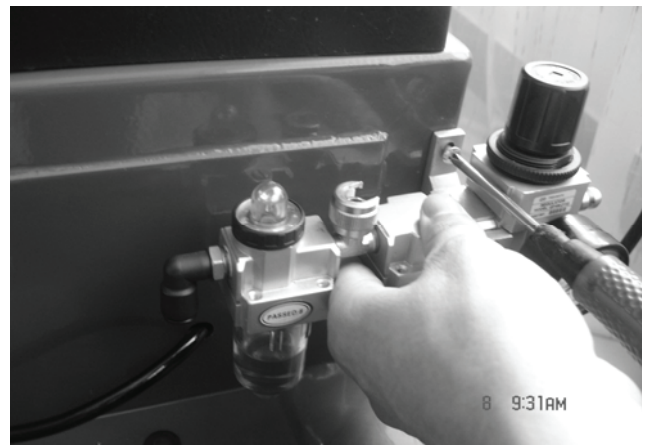

FIG 12

STEP 8: Connect the air hose. Detach the adapter on the Ø8 hose on the side wall of the body and insert it into the elbow (Fig 13/14). The adapter is to keep the hose from sliding into the body.

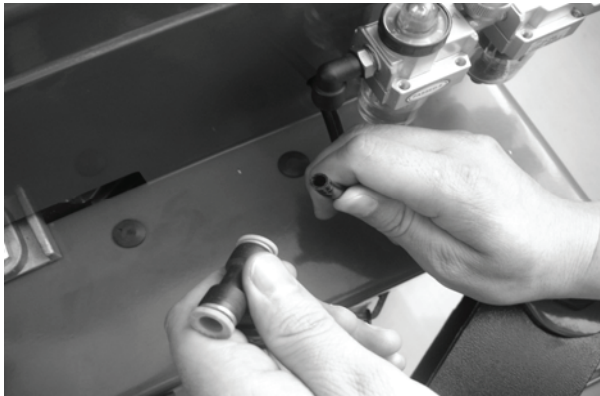

FIG 13

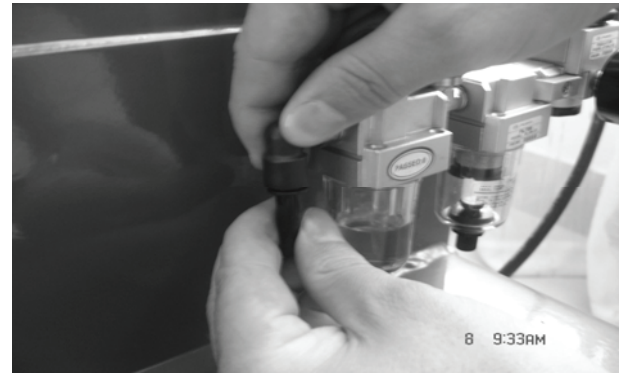

FIG 14

STEP 9: Connect the inflation gun. Inlay the adapter of the inflation gun into the groove (Fig 15) on the open nut on the air source fitting. Tighten the open nut and then connect the air source.

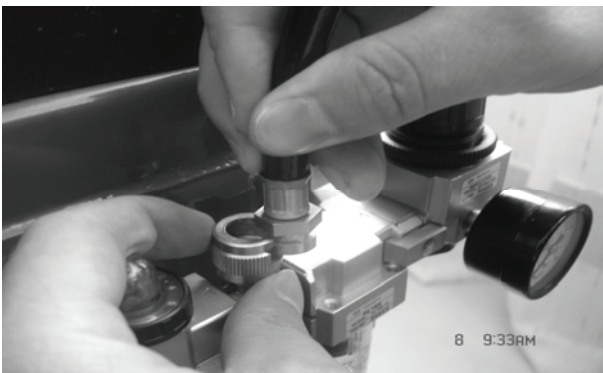

FIG 15

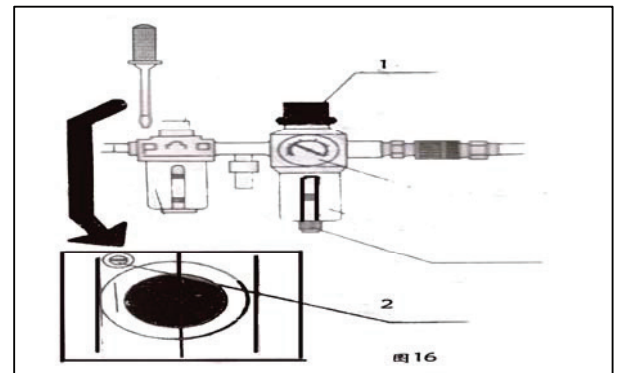

FIG 16

STEP 10: Air source has been adjusted before leaving the factory. If it needs changed, adjust again. **PRESSURE:** Lift up the pressure adjustable button (Fig 16-1) and twist clockwise and the air pressure will increase. Twist counterclockwise, and the air pressure will decrease. **OIL FEED:** Use screw driver to twist the screw (Fig 16-2) clockwise to decrease the oil feed or counterclockwise to increase the oil feed.

5. OPERATION INSTRUCTIONS

5.1 DISMOUNTING A TIRE

STEP 1: Deflate the air in the tire completely by pulling out the valve stem core. Use the special tool to detach the weight from the wheel (Fig 17).

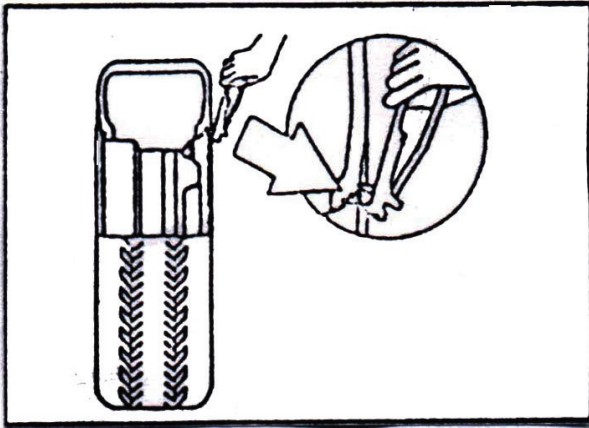

FIG 17

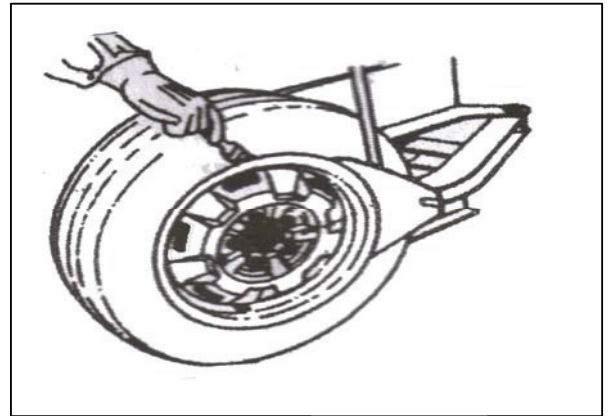

FIG 18

STEP 2: Place the tire between the bead breaking blade and rubber pad on the side of the machine (Fig 18). Then press down the bead breaker pedal to detach the wheel from the tire (Fig 2-10). Repeat the same operation on the other parts of the tire making sure the tire completely detaches from the wheel. Place the wheel with and tire on the turntable and press the clamp pedal (Fig 2-9) to securely clamp the wheel. Based on the specifications of the wheel you are servicing, choose either the outer clamping method or the inner clamping method. To detach the tire easily, you can use the brush to spread lubricant or thick soap liquid between the bead of the tire and wheel.

STEP 3: Position the hexangular shaft (Fig 2-3) to the working position to make the dismounting head close to the rim of the wheel. Use the hand wheel (Fig 7-2) to push against the rocker arm and then use the lock handle (Fig 2-12) to lock. The dismounting head will automatically move slightly (Fig 19). The angle of the dismounting head has been designed according to the standard wheel (13"). If handling a larger or smaller wheel, you may need to reposition the head.

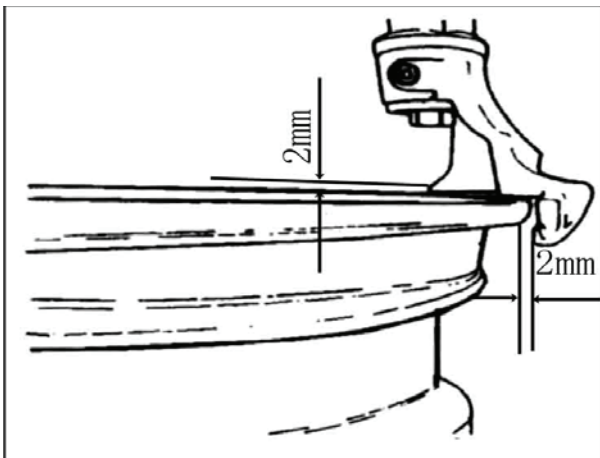

FIG 19

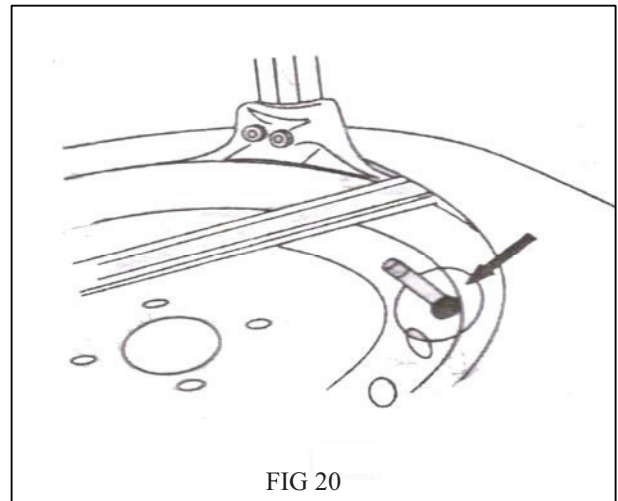

FIG 20

STEP 4: Use the tire iron to detach the lip of the tire up to the curve of the dismount head (Fig 20). Press the turntable rotation pedal (Fig 2-8) to rotate the turntable clockwise until the entire lip is completely detached. If handling a tire with a tube, avoid damage to the tube by keeping the nozzle of the tire 4" from the right side of the dismount head during the dismounting process. If the tire gets jammed, stop the machine immediately. Then lift up on the turntable rotation pedal to let the turntable rotate counterclockwise to reduce the resistance.

STEP 5: When handling a tire with a tube, take out the tube and then move the lower lip upwards to the upper edge of the wheel. Then repeat the steps above to detach the lower lip. **NOTE: During the dismounting process, keep your hands and other parts of your body away from moving parts. Make sure any clothing, jewelry or hair is kept away from moving parts as this will cause injury to personnel.**

5.2 MOUNTING A TIRE

STEP 1: Before mounting the tire, make sure the tire and wheel are the same dimension. Clean any debris from the wheel, then clamp it into position using the clamping jaws on the turntable.

STEP 2: Spread the lubrication liquid or soap liquid around the lip of the tire. Tilt the tire against the wheel and keep the front end upwards. Press down the hexangular shaft to move the dismounting arm into contact with the wheel and lock it in place. Position the left tire lip above the tail of the dismounting head and the right tire lip under the front end of the dismounting head (Fig 21). Rotate the turntable clockwise to guide the bottom lip into the tire detaching slot.

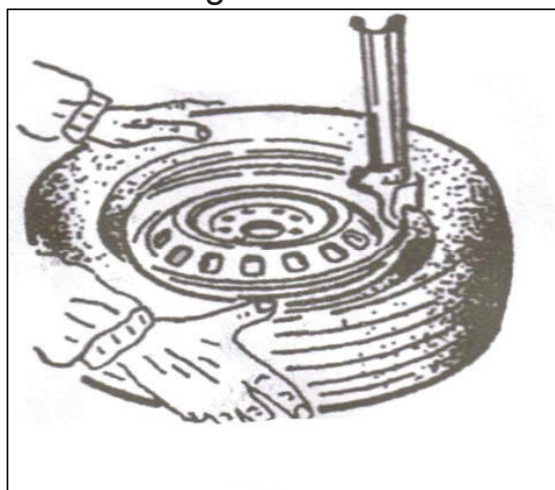
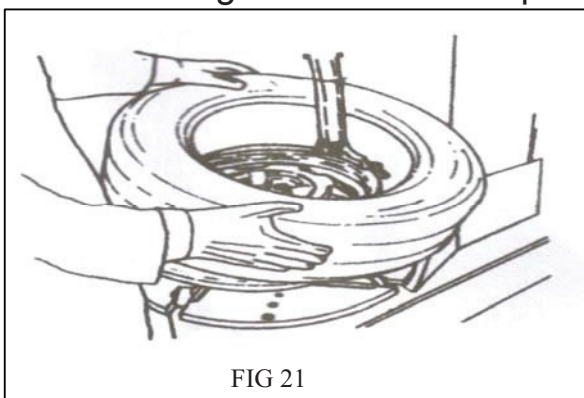

5.3 INFLATING A TIRE

STEP 1: Check that the air connection is good. This machine is equipped with an inflation guage for monitoring the air pressure in the tire.



FIG 23

STEP 2: Unclamp the wheel from the turntable. Connect the inflation hose to the tire air core (Fig 23).

STEP 3: Pull the inflation trigger to begin inflating the tire. Monitor the pressure guage to ensure that you do not exceed the tire's max pressure rating while attempting to seat the bead of the tire. To let air out of the tire, remove the valve stem.

6. MAINTENANCE



WARNING: DISCONNECT THE POWER AND AIR BEFORE SERVICING THE MACHINE.



IMPORTANT: THE MAINTENANCE INTERVALS INDICATED BELOW APPLY TO AVERAGE WORKSHOP USE. THE LIFT SHOULD BE INSPECTED MORE FREQUENTLY FOR SEVERE USE APPLICATIONS.

6.1 MAINTENANCE SCHEDULE

It is important to keep the machine clean, dry, and well maintained by establishing a periodic preventive maintenance program to ensure trouble-free operation and long service life.

WEEKLY

1. Check the lubrication oil level in the oil supply. If the level is low, fill it with air tool oil.
2. Drain out any water or impurities out of the oil/water separator.
3. Check the tension of the drive belt and adjust if necessary. Adjust using nuts A and B to achieve proper tension (Fig 27).
4. Check for any loose bolts and nuts and tighten accordingly.

MONTHLY

1. Use diesel oil to clean the hexangular shaft (Fig 24). Use machine oil to lubricate.
2. Use diesel oil to clean the turntable claw and its guide. Use lithium base oil to lubricate (Fig 25).

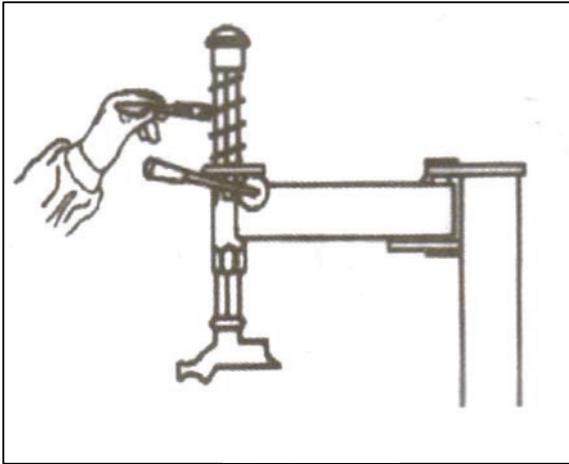

FIG 24

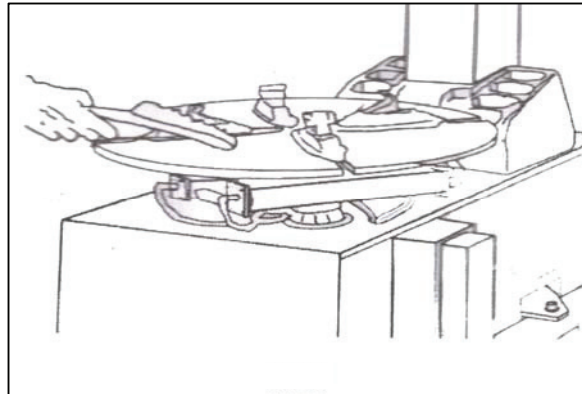

FIG 25

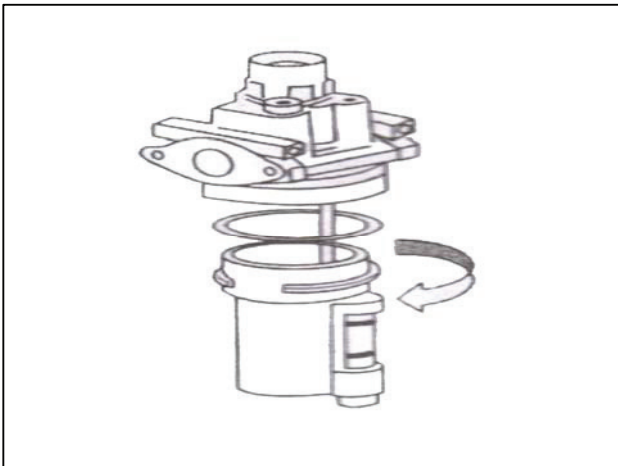

FIG 26

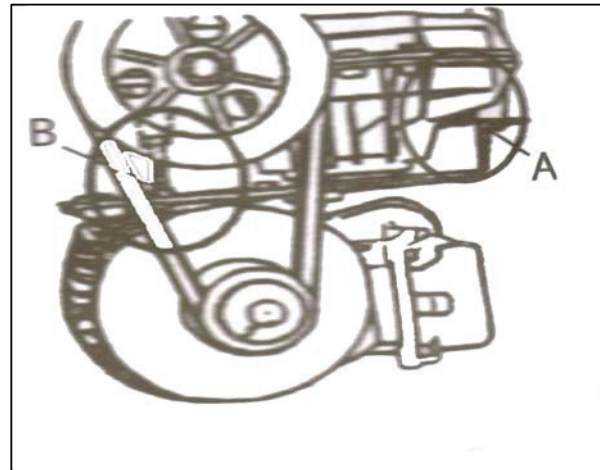

FIG 27

6.2 HEXANGULAR SHAFT & LOCK PLATE GAP ADJUSTMENT

Press downward on the hexangular lock handle and the hexangular shaft will slide vertically. Rotate the lock handle clockwise about 100° and the cam connected to the handle will push up the lock plate to lock the hexangular shaft. If you are unable to rotate the lock handle far enough, you can lock the hexangular shaft by adjusting the position of the the screws and nuts (Fig 28).

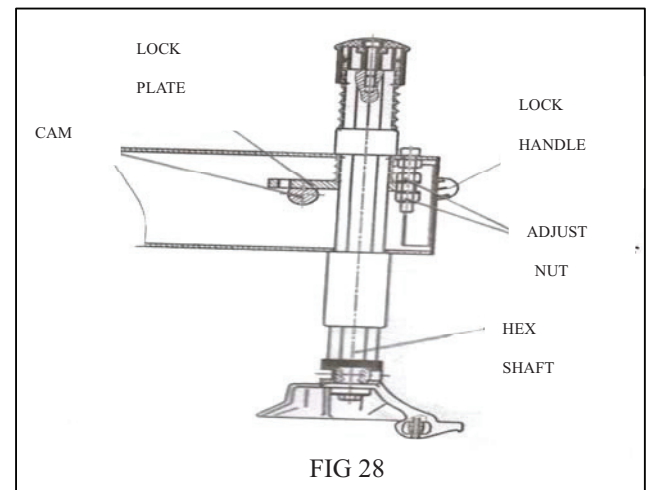
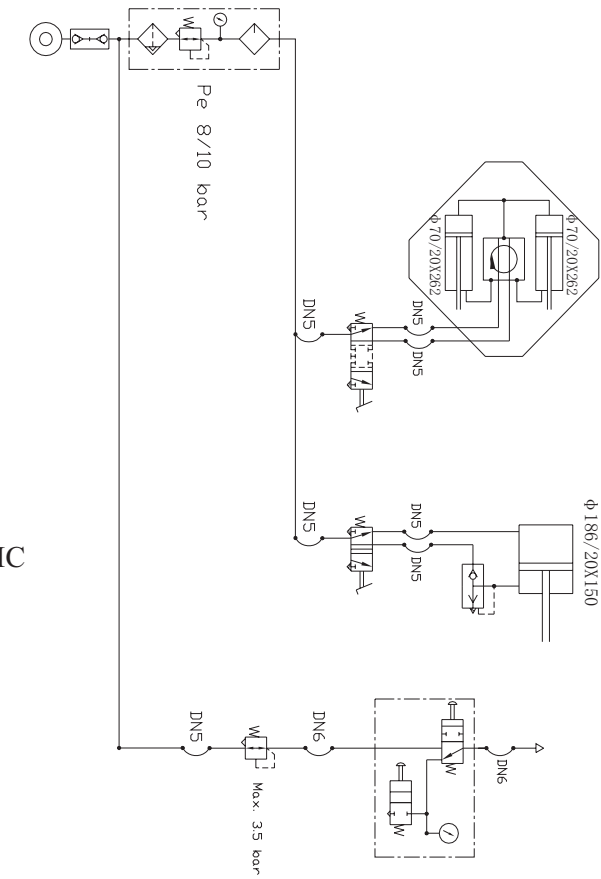
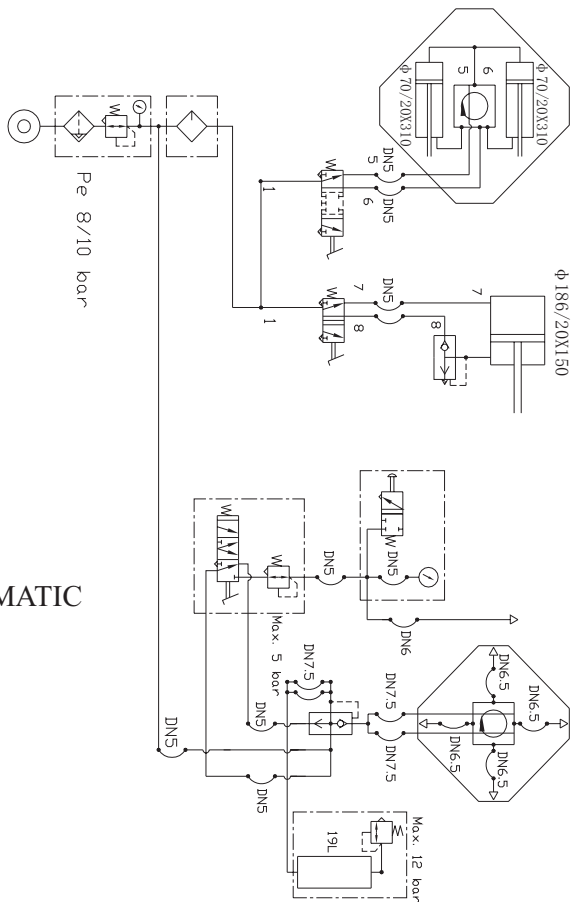

FIG 28

SEMI AUTOMATIC PNEUMATIC



SEMI AUTOMATIC PNEUMATIC (IT)



0	1	2	3	4	5	6
FILTER- GRUOP	TILTING	LOCKING RIMS	BEAD BREAKER	ARM LOCKING	TIRE GAUGE	BEAD SEATER
	RISE ↓ DESCENT ↑	OPEN ← CLOSED →	OPEN ← CLOSED →	LOCKING ← DECHUCKING →		

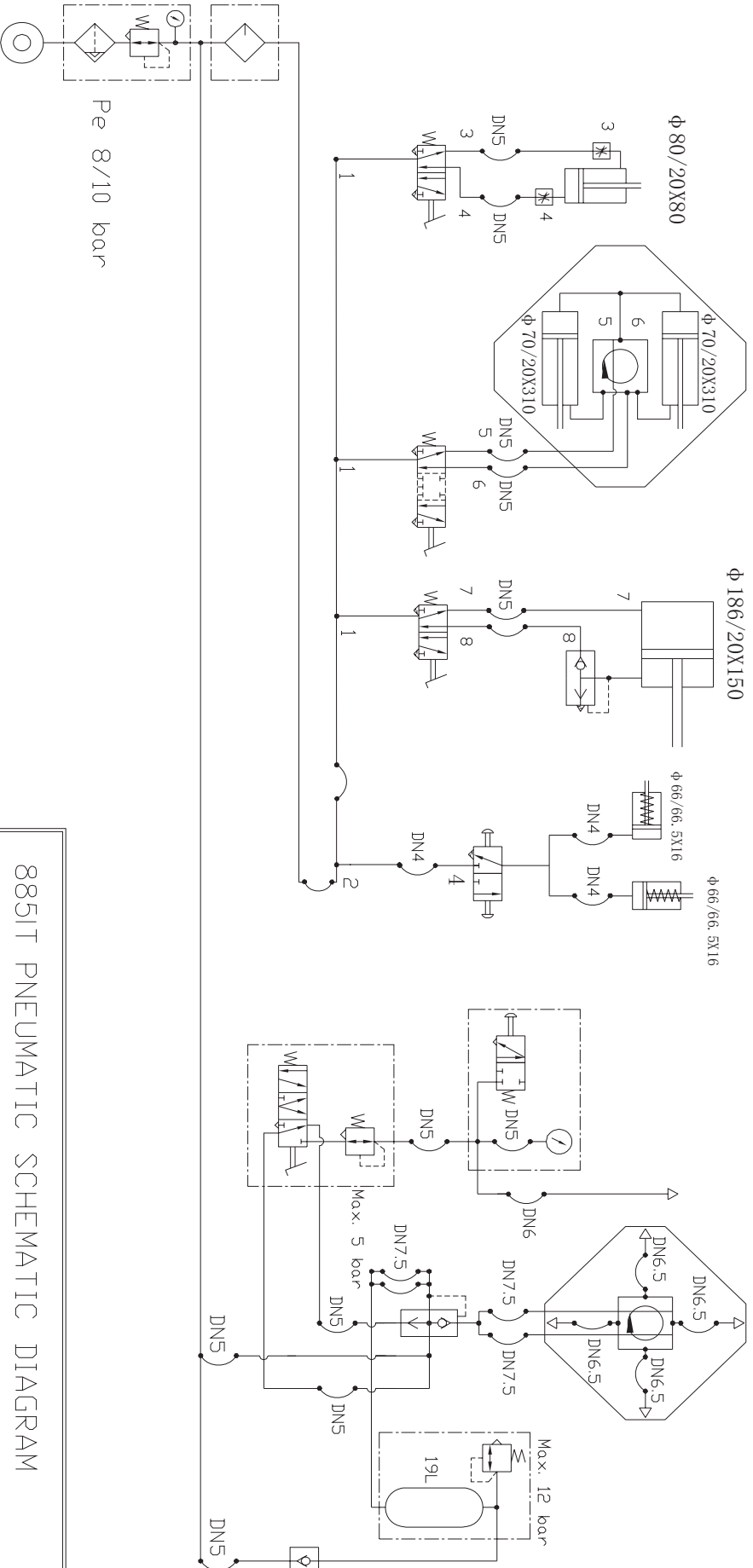

8851T PNEUMATIC SCHEMATIC DIAGRAM

7. TROUBLESHOOTING

Symptom	Reason	Solution
Turntable only rotates in one direction.	Universal switch contact is bad.	Install new universal switch.
Turntable does not rotate.	Belt damage. Belt too loose. Bad motor or power source. Universal switch contact damage.	Change belt. Adjust belt tension. Check motor, power source & cable. Replace motor if bad. Install new universal switch.
Turntable cannot clamp the wheel normally.	Claw worn. Clamp cylinder air leakage.	Install new claws. Fix air leakage sealing parts.
Hexangular shaft cannot lock.	Lock plate not in position.	Refer to Page 13.
Chassis pedal does not return to starting position.	Pedal return spring damage.	Install new return spring.
Motor not rotating or low torque output.	Drive system jam. Capacitor broken down. Not enough voltage. Short-circuit.	Remove the jam. Install new capacitor. Wait for voltage to return. Remove.
Low cylinder output force.	Air leakage. Mechanic fault. Low air pressure.	Change sealing parts. Remove the fault. Adjust the air pressure.
Air Leakage	Air hose broken. Pipe fitting broken. Sealing head broken. Loss of sealing glue.	Change broken parts. Refill sealing glue.

MACHINE OIL SAFETY DATA SHEET

MOBIL XHP 222

ITEM	QUALITY STANDARD
Penetration rate 25□ mm/10	280
dropping point □	280
anticorrosion	passed
Basic oil viscosity	220
oxidize stability 100h pressure-drop kpa	35
water lose percentage 79%	5
copper corrosion	1A

SAE30# LUBRICATION OIL

ITEM	QUALITY STANDARD
density 15□	0.893
Flash point	224
Pour point □	-18
viscosity 40□	100
viscosity 100□	11.2
Viscosity index	97

2# LITHIUM BASE GREASE

ITEM	QUALITY STANDARD
Penetration rate mm/10	278
dropping point □	187
copper corrosion 100□ 24 h	No change
oxidize stability (99□ 100 h)	0.2
anticorrosion (52□ 48 h)	1 level
similarity viscosity (-15□、 $10S^{-1}$) / (Pa·S)	800
water lose(35□ 1h) %	8

CKC460 INDUSTRIAL GEAR OIL

ITEM	QUALITY STANDARD
Viscosity 40□	461
Viscosity index	92
Flash point □	212
Freezing point □	-26
copper corrosion 100□ 3 h	1A
mechanical impurity	0.007
Pour point	-10



LIMITED WARRANTY

The **Titan 2 Post lifts and 4 Post lifts** are backed by a standard **1 year** replacement parts warranty and a **5 year** structural warranty from the date of purchase, to the original purchaser only. The **1 year** replacement parts warranty covers power units, hydraulic cylinders, and all other assembly components such as, but not limited to: turn plates, slip plates, cables, chains, valves, switches etc. This does not cover normal wear items such as but not limited to rubber lifting pads and nylon slide blocks. Titan **HD2P-9000ACE-D** and **HD2P-9000AFE 2 Post lifts** are backed by a **2 year** replacement parts warranty and a **5 year** structural warranty from the date of purchase, to the original purchaser only. The **2 year** replacement parts warranty covers power units, hydraulic cylinders, and all other assembly components such as, but not limited to: turn plates, slip plates, cables, chains, valves, switches etc. This does not cover normal wear items such as but not limited to rubber lifting pads and nylon slide blocks.

Titan Mid Rise Scissor lifts are backed by a standard **1 year** replacement parts warranty and a **5 year** structural warranty from the date of purchase, to the original purchaser only. The **1 year** replacement parts warranty covers power units, hydraulic cylinders, and all other assembly components such as, but not limited to: turn plates, slip plates, cables, chains, valves, switches etc. This does not cover normal wear items such as but not limited to rubber lifting pads and nylon slide blocks.

Titan Standard Duty and Heavy Duty motorcycle lifts are backed by a standard **1 year** replacement parts warranty from the date of purchase, to the original purchaser only. The **1 year** replacement parts warranty covers power units, hydraulic cylinders, pneumatic cylinders, and all other assembly components such as, but not limited to: cables, caster wheels, valves, switches, wheel vises etc. This does not cover normal wear items such as but not limited to rubber wheel vise pads.

Titan Bulldog Moto Cradle Wheel Chock is warranted for replacement parts, only to the original purchaser, for a period of **2 years** from the date of purchase.

Titan shop equipment products and accessories are warranted for replacement parts only to the original purchaser for a period of **90 days** from the date of purchase. This **90 day** replacement parts warranty covers products such as but not limited to: EZ mover jacks, Mini Jacks, tie down products, shop and Bulldog Moto Cradle Wheel Chock accessories, dollies, stands, Light Duty Motorcycle Lifts, etc.

For **all** warranty considerations, Titan Marketing, LLC will supply replacement parts only during the warranty period. The original purchaser is responsible for all shipping, handling, and any labor charges incurred. All defective parts must be returned to Titan for inspection and examination. Any parts that are found to be defective will be replaced or repaired to proper working order. Other items not listed above may be considered general wear parts and therefore, will not be covered under warranty. These warranties **do not** extend to **defects** caused by ordinary wear, abuse, misuse, shipping damage, improper installation, voltage or lack of required maintenance. Titan Marketing, LLC is **not** to be held responsible for any **failure** that results from an accident, purchaser/operator abuse, neglect, or failure to operate products in accordance with instructions provided in the owner's manual(s) supplied. Damage caused by rain, excessive humidity, corrosive environments or other contaminants are not covered under warranty. **THESE WARRANTIES DO NOT EXTEND TO ANY COSMETIC DEFECT NOT INTERFERING WITH EQUIPMENT FUNCTIONALITY OR ANY INCIDENTAL, INDIRECT, OR CONSEQUENTIAL LOSS, DAMAGE, OR EXPENSE THAT MAY RESULT FROM ANY DEFECT, FAILURE OR MALFUNCTION OF A TITAN MARKETING LLC PRODUCT OR THE BREACH OR DELAY IN PERFORMANCE OF THE WARRANTY.**



WARNING



The warnings, precautions and instructions in this manual cannot cover all possible conditions and situations that may occur. The operator must understand that the operator must supply common sense and examine caution factors when using this product to determine safety in all circumstances being used.



TITAN MARKETING, LLC

PO Box 7069 Greenwood, IN 46142
1.888.908-4826 FAX (317) 215.2770
www.titanlifts.com

**Patent No.: US 8,104,588 B2
CA 2,729,670**

Copyright © 2015 by Titan Marketing, LLC. All rights reserved. No portion of this manual or any artwork contained herein may be reproduced in any shape or form without the express consent of Titan Marketing, LLC. Diagrams within this manual may not be drawn proportionally. Due to continuing improvements, actual product may differ slightly from the product described herein. Tools required for assembly and service may not be included.